

INTERNATIONAL
STANDARD

ISO
9906

First edition
1999-12-15

**Rotodynamic pumps — Hydraulic
performance acceptance tests — Grades 1
and 2**

*Pompes rotodynamiques — Essais de fonctionnement hydraulique pour
la réception — Niveaux 1 et 2*



Reference number
ISO 9906:1999(E)

Contents

1 Scope	1
2 Normative references	1
3 Terms, definitions and symbols	2
4 Guarantees	8
4.1 Subjects of guarantees	8
4.2 Other conditions of guarantee	8
5 Execution of tests	8
5.1 Subjects of tests	8
5.2 Organization of tests	9
5.3 Test arrangements	11
5.4 Test conditions	13
6 Analysis of test results	17
6.1 Translation of the test results to the guarantee conditions	17
6.2 Measuring uncertainties	18
6.3 Values of tolerance factors	20
6.4 Verification of guarantees	20
6.5 Obtaining specified characteristics	21
7 Measurement of flow rate	22
7.1 Measurement by weighing	22
7.2 Volumetric method	22
7.3 Differential pressure devices	22
7.4 Thin-plate weirs	23
7.5 Velocity area methods	23

© ISO 1999

All rights reserved. Unless otherwise specified, no part of this publication may be reproduced or utilized in any form or by any means, electronic or mechanical, including photocopying and microfilm, without permission in writing from the publisher.

International Organization for Standardization
Case postale 56 • CH-1211 Genève 20 • Switzerland
Internet iso@iso.ch

Printed in Switzerland

7.6 Tracers methods	23
7.7 Other methods	23
8 Measurement of pump total head	24
8.1 General	24
8.2 Definition of the measuring sections	25
8.3 Water level measurement	30
8.4 Pressure measurements	31
9 Measurement of speed of rotation	34
10 Measurement of pump power input	35
10.1 General	35
10.2 Measurement of torque	35
10.3 Electric power measurements	35
10.4 Special cases	35
11 Cavitation tests	36
11.1 General	36
11.2 Test installations	38
11.3 Determination of the NPSH required by the pump	39
Annex A (normative) Tolerance factors for pumps produced in series with selection made from typical performance curves and for pumps with a driver power input less than 10 kW (relevant to series pumps grade 2)	42
Annex B (normative) Determination of reduced impeller diameters	43
Annex C (normative) Friction losses	44
Annex D (informative) Conversion to SI units	49
Annex E (informative) Guide for suitable time periods between calibrations of test instruments	50
Annex F (informative) Costs and repetition of tests	51
Annex G (informative) Performance correction chart for viscous liquids	52
Annex H ((informative) NPSHR reduction for pumps handling hydrocarbon liquids and high temperature water	55
Annex I (informative) Statistical evaluation of measurement results	57
Annex J (informative) Pump test sheet	59
Annex K (informative) Checklist	60
Bibliography	61

Foreword

ISO (the International Organization for Standardization) is a worldwide federation of national standards bodies (ISO member bodies). The work of preparing International Standards is normally carried out through ISO technical committees. Each member body interested in a subject for which a technical committee has been established has the right to be represented on that committee. International organizations, governmental and non-governmental, in liaison with ISO, also take part in the work. ISO collaborates closely with the International Electrotechnical Commission (IEC) on all matters of electrotechnical standardization.

International Standards are drafted in accordance with the rules given in the ISO/IEC Directives, Part 3.

Draft International Standards adopted by the technical committees are circulated to the member bodies for voting. Publication as an International Standard requires approval by at least 75 % of the member bodies casting a vote.

International Standard ISO 9906 was prepared by Technical Committee ISO/TC 115, *Pumps*, Subcommittee SC 2, *Methods of measuring and testing*.

This first edition of ISO 9906 cancels and replaces ISO 2548:1975 and ISO 3555:1977, which have been combined and technically revised (see Introduction).

Annexes A, B and C form a normative part of this International Standard. Annexes D to K are for information only.

Introduction

This International Standard combines and replaces the former acceptance test standards ISO 3555:1977 (corresponding to grade 1 of this International Standard) and ISO 2548:1975 (corresponding to grade 2 of this International Standard), but there is an important change in the verification of guarantees, because the uncertainty of measurement must not influence the acceptability of a pump and the tolerances are due to constructional differences only.

New tolerance factors have been introduced to ensure as far as possible that a pump which was acceptable under the previous International Standards (ISO 2548 and/or ISO 3555) would also be acceptable under this International Standard.

Contrary to this International Standard, ISO 5198 is not to be understood as an acceptance test code. It gives guidance for measurements of very high accuracy and for the thermodynamic method for direct measurement of efficiencies, but it does not recommend verification of guarantees.

Terms used in this International Standard such as "guarantee" or "acceptance" should be understood in a technical but not in a legal sense. The term "guarantee" therefore specifies values for checking purposes determined in the contract, but does not say anything about the rights or duties arising, if these values are not reached or fulfilled. The term "acceptance" does not have any legal meaning here, either. Therefore, an acceptance test carried out successfully alone does not represent an "acceptance" in the legal sense.

Rotodynamic pumps — Hydraulic performance acceptance tests — Grades 1 and 2

1 Scope

This International Standard specifies hydraulic performance tests for acceptance of rotodynamic pumps (centrifugal, mixed flow and axial pumps, hereinafter simply designated as "pumps"). It is applicable to pumps of any size and to any pumped liquids behaving as clean cold water (such as defined in 5.4.5.2). It is neither concerned with the structural details of the pump nor with the mechanical properties of their components.

This International Standard contains two grades of accuracy of measurement: grade 1 for higher accuracy, and grade 2 for lower accuracy. These grades include different values for tolerance factors, for allowable fluctuations and uncertainties of measurement.

For pumps produced in series with selection made from typical performance curves and for pumps with power input of less than 10 kW, see annex A for higher tolerance factors.

This International Standard is applicable both to a pump itself without any fittings and to a combination of a pump associated with all or part of its upstream and/or downstream fittings.

2 Normative references

The following normative documents contain provisions which, through reference in this text, constitute provisions of this International Standard. For dated references, subsequent amendments to, or revisions of, any of these publications do not apply. However, parties to agreements based on this International Standard are encouraged to investigate the possibility of applying the most recent editions of the normative documents indicated below. For undated references, the latest edition of the normative document referred to applies. Members of ISO and IEC maintain registers of currently valid International Standards.

ISO 1438-1, *Water flow measurement in open channels using weirs and Venturi flumes — Part 1: Thin-plate weirs.*

ISO 2186, *Fluid flow in closed conduits — Connections for pressure signal transmissions between primary and secondary elements.*

ISO 3354, *Measurement of clean water flow in closed conduits — Velocity-area method using, current-meters in full conduits and under regular flow conditions.*

ISO 3966, *Measurement of fluid flow in closed conduits — Velocity area method using Pitot static tubes.*

ISO 4373, *Measurement of liquid flow in open channels — Water-level measuring devices.*

ISO 5167-1, *Measurement of fluid flow by means of pressure differential devices — Part 1: Orifice plates, nozzles and Venturi tubes inserted in circular cross-section conduits running full.*

ISO 5198, *Centrifugal, mixed flow and axial pumps — Code for hydraulic performance tests — Precision grade.*

ISO 7194, *Measurement of fluid flow in closed conduits — Velocity-area methods of flow measurement in swirling or asymmetric flow conditions in circular ducts by means of current-meters or Pitot-static tubes.*

ISO 8316, *Measurement of liquid flow in closed conduits — Method by collection of the liquid in a volumetric tank.*

ISO 9104, *Measurement of liquid flow in closed conduits — Methods of evaluating the performance of electromagnetic flow-meters for liquids.*

IEC 60034-2, *Recommendations for rotating electrical machinery (excluding machines for traction vehicles) — Part 2: Determination of efficiency of rotating electrical machinery.*

IEC 60051, *Recommendations for direct acting electrical measuring instruments and their accessories.*

3 Terms, definitions and symbols

For the purposes of this International Standard, the following terms, definitions and symbols apply.

NOTE 1 The definitions, particularly those given for head and net positive suction head (NPSH), may not be appropriate for general use in hydrodynamics, and are for the purposes of this International Standard only. Some terms in current use but not strictly necessary for the use of this International Standard are not defined.

NOTE 2 Table 1 gives an alphabetical list of symbols used, and Table 2 gives a list of subscripts. In this International Standard all formulae are given in coherent SI units. For conversion of other units to SI units, see annex D.

NOTE 3 In order to avoid any error of interpretation, it is deemed desirable to reproduce the definitions of quantities and units as given in ISO 31 and to supplement these definitions by some specific information on their use in this International Standard.

3.1

angular velocity

number of radians of a shaft per unit time

$$\omega = 2\pi n$$

3.2

speed of rotation

number of rotations per unit time

3.3

density

mass per unit volume

3.4

pressure

force per unit area

NOTE In this International Standard all pressures are gauge pressures, i.e. measured with respect to the atmospheric pressure, except for atmospheric pressure and the vapour pressure which are absolute pressures.

3.5

power

energy transferred per unit time

3.6

Reynolds number

$$Re = \frac{UD}{\nu}$$

3.7

mass flow rate

external mass flow rate of the pump, i.e. the rate of flow discharged into the pipe from the outlet branch of the pump

NOTE 1 The following losses or abstractions are inherent to the pump:

- a) discharge necessary for hydraulic balancing of axial thrust;
- b) cooling of bearings of the pump itself;
- c) liquid seal to the packing.

NOTE 2 Leakage from the fittings, internal leakage, etc., are not to be reckoned in the rate of flow. On the contrary, all derived flows for other purposes, such as

- cooling of the motor bearings;
- cooling of a gear box (bearings, oil cooler), etc.

are to be reckoned in the rate of flow.

NOTE 3 Whether and how these flows are to be taken into account depends on the location of their derivation and of the section of flow-measurement, respectively.

3.8

volume flow rate

outlet volume flow rate has the following value:

$$Q = \frac{q}{\rho}$$

NOTE In this International Standard the symbol Q may also designate the volume flow rate in any given section. It is the quotient of the mass flow rate in this section and the density. (The section may be designated by subscripts.)

3.9

mean velocity

mean axial velocity of flow equal to the volume flow rate divided by the pipe cross section area

$$U = \frac{Q}{A}$$

NOTE Attention is drawn to the fact that in this case Q may vary for different reasons across the circuit.

3.10

local velocity

velocity of flow at any point

3.11

head

energy per unit mass of fluid, divided by acceleration due to gravity, g

3.12

reference plane

any horizontal plane used as a datum for height measurement

NOTE For practical reasons it is preferable not to specify an imaginary reference plane.

3.13

height above reference plane

height of the considered point above the reference plane

NOTE Its value is:

- positive, if the considered point is above the reference plane;
- negative, if the considered point is below the reference plane.

See Figures 3 and 4.

3.14 gauge pressure

pressure relative to atmospheric pressure

NOTE 1 Its value is:

- positive, if this pressure is greater than the atmospheric pressure;
- negative, if this pressure is less than the atmospheric pressure.

NOTE 2 All pressures in this International Standard are gauge pressures read from a manometer or similar pressure-sensing instrument, except atmospheric pressure and the vapour pressure of the liquid, which are expressed as absolute pressures.

3.15 velocity head

kinetic energy per unit mass of the liquid in movement, divided by g :

$$\frac{U^2}{2g}$$

3.16 total head

in any section, the total head is given by:

$$H_x = z_x + \frac{p_x}{\rho g} + \frac{U_x^2}{2g}$$

where z is the height of the centre of the cross-section above the reference plane and p is the gauge pressure related to the centre of the cross-section

NOTE The absolute total head in any section is given by:

$$H_{x(\text{abs})} = z_x + \frac{p_x}{\rho g} + \frac{p_{\text{amb}}}{\rho g} + \frac{U_x^2}{2g}$$

3.17 inlet total head

total head in the inlet section of the pump:

$$H_1 = z_1 + \frac{p_1}{\rho g} + \frac{U_1^2}{2g}$$

3.18 outlet total head

total head in the outlet section of the pump:

$$H_2 = z_2 + \frac{p_2}{\rho g} + \frac{U_2^2}{2g}$$

3.19 pump total head

algebraic difference between the outlet total head H_2 and the inlet total head H_1

NOTE 1 If the compressibility is negligible, $H = H_2 - H_1$.

If the compressibility of the pumped liquid is significant, the density ρ should be replaced by the mean value:

$$\rho_m = \frac{\rho_1 + \rho_2}{2}$$

and the pump total head should be calculated by the formula:

$$H = z_2 - z_1 + \frac{p_2 - p_1}{\rho_m \cdot g} + \frac{U_2^2 - U_1^2}{2g}$$

NOTE 2 The mathematically correct symbol would be $H_{1,2}$.

3.20 specific energy

energy per unit mass of liquid:

$$y = gH$$

3.21 loss of head at inlet

difference between the total head of the liquid at the measuring point and the total head of the liquid in the inlet section of the pump

3.22 loss of head at outlet

difference between the total head of the liquid in the outlet section of the pump and the total head of the liquid at the measuring point

3.23 pipe friction loss coefficient

coefficient for the head loss by friction in the pipe

3.24 net positive suction head NPSH

absolute inlet total head above the head equivalent to the vapour pressure relative to the NPSH datum plane:

$$\text{NPSH} = H_1 - z_D + \frac{p_{\text{amb}} - p_v}{\rho_1 g}$$

NOTE This NPSH relates to the NPSH datum plane, whereas the inlet total head relates to the reference plane.

3.25 NPSH datum plane

<multistage pumps> horizontal plane through the centre of the circle described by the external points of the entrance edges of the impeller blades

3.26 NPSH datum plane

<double inlet pumps with vertical or inclined axis> plane through the higher centre

NOTE The manufacturer should indicate the position of this plane with respect to precise reference points on the pump.

See Figure 1.

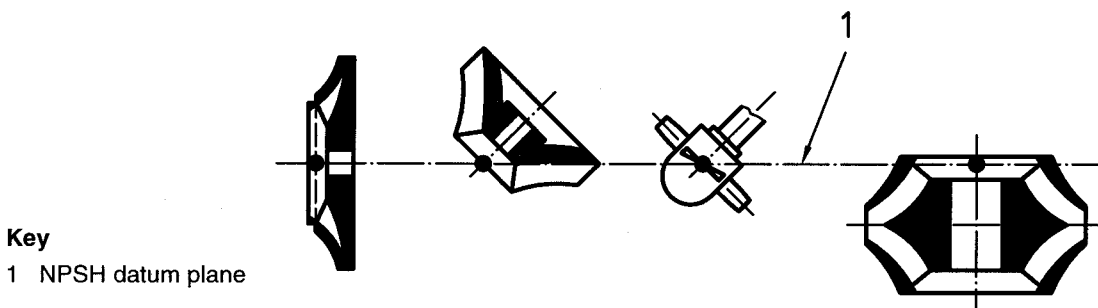

Key

1 NPSH datum plane

Figure 1 — NPSH datum plane

3.27
available NPSH
NPSHA

NPSH available as determined by the conditions of the installation for a specified flow rate

3.28
required NPSH
NPSHR

minimum NPSH given by the manufacturer/supplier for a pump achieving a specified performance at a specified flow rate, speed and pumped liquid (occurrence of visible cavitation, increase of noise and vibration due to cavitation, beginning of head or efficiency drop, head or efficiency drop of a given amount, limitation of cavitation erosion)

3.29
NPSH3

NPSH required for a drop of 3 % of the total head of the first stage of the pump as standard basis for use in performance curves

3.30
type number

dimensionless quantity calculated at the point of best efficiency which is defined by the following formula:

$$K = \frac{2 \pi n Q'^{1/2}}{(gH')^{3/4}} = \frac{\omega Q'^{1/2}}{y'^{3/4}}$$

where Q' is the volume rate of flow per eye and H' is the head of the first stage

NOTE The type number is to be taken at maximum diameter of the first stage impeller.

3.31
pump power input

power transmitted to the pump by its driver

3.32
pump power output

mechanical power transferred to the liquid during its passage through the pump:

$$P_u = \rho Q g H = \rho Q y$$

3.33
driver power input

power absorbed by the pump driver

3.34
pump efficiency

pump power output divided by the pump power input

$$\eta = \frac{P_u}{P}$$

3.35
overall efficiency

pump power output divided by the driver power input

$$\eta_{gr} = \frac{P_u}{P_{gr}}$$

Table 1 — Alphabetical list of basic letters used as symbols

Symbol	Quantity	Unit
<i>A</i>	Area	m ²
<i>D</i>	Diameter	m
<i>E</i>	Energy	J
<i>e</i>	Overall uncertainty, relative value	%
<i>f</i>	Frequency	s ⁻¹ , Hz
<i>g</i>	Acceleration due to gravity ^a	m/s ²
<i>H</i>	Pump total head	m
<i>H_J</i>	Losses in terms of head of liquid	m
<i>k</i>	Equivalent uniform roughness	m
<i>K</i>	Type number	(pure number)
<i>l</i>	Length	m
<i>m</i>	Mass	kg
<i>n</i>	Speed of rotation	s ⁻¹ , min ⁻¹
NPSH	Net positive suction head	m
<i>p</i>	Pressure	Pa
<i>P</i>	Power	W
<i>q</i>	Mass flow rate ^b	kg/s
<i>Q</i>	Volume flow rate ^c	m ³ /s
<i>Re</i>	Reynolds number	(pure number)
<i>t</i>	Tolerance factor, relative value	%
<i>t</i>	Time	s
<i>T</i>	Torque	Nm
<i>U</i>	Mean velocity	m/s
<i>v</i>	Local velocity	m/s
<i>V</i>	Volume	m ³
<i>y</i>	Specific energy	J/kg
<i>z</i>	Height above reference plane	m
<i>z_D</i>	Difference between NPSH datum plane (see 3.25) and reference plane	m
<i>η</i>	Efficiency	(pure number)
<i>θ</i>	Temperature	°C
<i>λ</i>	Pipe friction loss coefficient	(pure number)
<i>ν</i>	Kinematic viscosity	m ² /s
<i>ρ</i>	Density	kg/m ³
<i>ω</i>	Angular velocity	rad/s

^a In principle, the local value of *g* should be used. Nevertheless, for grade 2 it is sufficient to use a value of 9,81 m/s². For the calculation of the local value $g = 9,780\ 3 (1 + 0,005\ 3 \sin^2\varphi) - 3 \times 10^{-6} \cdot z$, where φ is the latitude and *z* is the altitude.

^b An optional symbol for mass rate of flow is *q_m*.

^c An optional symbol for volume rate of flow is *q_v*.

Table 2 — List of letters and figures used as subscript

Subscript	Meaning
1	inlet
1'	inlet measuring section
2	outlet
2'	outlet measuring section
abs	absolute
amb	ambient
D	difference, datum
f	fluid in measuring pipes
G	guaranteed
<i>H</i>	pump total head
gr	combined motor/pump unit (overall)
m	mean
M	manometer
<i>n</i>	speed of rotation
<i>P</i>	power
<i>Q</i>	(volume) flow rate
sp	specified
T	translated, torque
u	useful
v	vapour (pressure)
<i>η</i>	efficiency
<i>x</i>	at any section

4 Guarantees

4.1 Subjects of guarantees

One guarantee point shall be defined by a guarantee flow Q_G and a guarantee head H_G .

The manufacturer/supplier guarantees that under the specified conditions and at the specified speed (or in some cases frequency and voltage) the measured $H(Q)$ curve will pass through a range of tolerance (see Table 10 and Figure 2), surrounding the guarantee point.

Other tolerance ranges (e.g. only given by positive tolerance factors) may be agreed upon in the contract.

In addition, one or more of the following quantities may be guaranteed under the specified conditions and at the specified speed:

- | | | |
|--------------------------------------------------------------------------------------------------------------------------------------------------------------------------------------------------------------------------------------------------------------------------------|---|-----------------------------------------------------------------|
| <ul style="list-style-type: none"> a) the pump efficiency, η_G, or in the case of overall pump driver unit, the combined efficiency, η_{grG}; b) the required net positive suction head (NPSHR) at the guarantee flow; | } | <p>at the flow rate which is defined in 6.4.2 and Figure 2.</p> |
|--------------------------------------------------------------------------------------------------------------------------------------------------------------------------------------------------------------------------------------------------------------------------------|---|-----------------------------------------------------------------|

By special agreement several guarantee points and the appropriate values of efficiency and required net positive suction head at reduced or increased flow rates may be guaranteed. The maximum power input may be guaranteed for the guarantee flow or for a range of operation. This, however, may require larger tolerance ranges to be agreed upon between the purchaser and manufacturer/supplier.

4.2 Other conditions of guarantee

Unless otherwise agreed, the following conditions shall apply to the guaranteed values.

- a) Unless the chemical and physical properties of the liquid being pumped are stated, the guarantee points shall apply to clean cold water (see 5.4.5.2).
- b) The relationship between the guarantee values under clean cold water conditions and the likely performance under other liquid conditions shall be agreed in the contract.
- c) Guarantees shall apply only to the pump as tested by the methods and in the test arrangements specified in this International Standard.
- d) The pump manufacturer/supplier shall not be responsible for the specification of the guarantee point.

5 Execution of tests

5.1 Subjects of tests

5.1.1 General

If not otherwise agreed between the manufacturer/supplier and the purchaser, the following shall apply:

- a) accuracy according to grade 2;
- b) tests shall be carried out on the test stand of the manufacturer's works;
- c) the NPSH test is not included.

Any deviations from this shall be agreed between the purchaser and manufacturer/supplier. This should be done as soon as possible, and should preferably form part of the contract.

Among others, such deviations may be:

- accuracy according to grade 1;

- no negative tolerance factors (see 4.1);
- tolerance factors corresponding to annex A;
- statistical evaluation of measurement results according to annex I;
- tests in a neutral laboratory or on site;
- deviations from the requirements concerning the installation of the pump and the measuring apparatus;
- simulated construction of pumps (e.g. several rotors in same casing);
- a requirement for the NPSH test.

Annex K shows a checklist of items where agreement between the purchaser and manufacturer/supplier is recommended.

5.1.2 Contractual tests — Fulfilment of the guarantee

The tests are intended to ascertain the performance of the pump and to compare this with the manufacturer's/supplier's guarantee.

The nominated guarantee for any quantity shall be deemed to have been met if, when tested according to this International Standard, the measured performance fails within the tolerance specified for the particular quantity (see clause 6).

When NPSHR is to be guaranteed, the type of test shall be specified (see 11.1.2).

When a number of identical pumps are to be purchased, the number of pumps to be tested shall be agreed between the purchaser and manufacturer/supplier.

5.1.3 Additional checks

During the test, it may be noted if the behaviour of the pump is satisfactory in respect of the temperature of packings and bearings, of leakage of air or water, of acoustic emission and of vibrations¹⁾.

5.2 Organization of tests

5.2.1 General

Both, purchaser and manufacturer/supplier shall be entitled to witness these tests.

5.2.2 Location of tests

5.2.2.1 Works tests

Performance tests should preferably be carried out at the manufacturer's works, or at a place to be mutually agreed between the manufacturer/supplier and the purchaser.

5.2.2.2 Site tests

Special agreement is necessary for performance tests on site providing all the requirements of this International Standard can be satisfied. It is, however, recognised that the conditions at most sites often preclude full compliance with this International Standard. In these instances site performance tests may still be acceptable providing the parties have agreed how allowance is made for the inaccuracies which will inevitably result from departure from the specified requirement.

1) Special International Standards for pumps are under study in ISO/TC 115.

5.2.3 Date of testing

The date of testing shall be mutually agreed by the manufacturer/supplier and the purchaser.

5.2.4 Staff

Accurate measurements depend not only on the quality of the measuring instruments used but also on the ability and skill of the persons operating and reading the measuring devices during the tests. The staff entrusted with effecting the measurements shall be selected just as carefully as the instruments to be used in the test.

Specialists with adequate experience in measuring operations in general shall be charged with operating and reading complicated measuring apparatus. Reading simple measuring devices may be entrusted to such helpers who (upon prior instruction) can be assumed to effect the readings with proper care and the accuracy required.

A test supervisor possessing adequate experience in measuring operations shall be mutually appointed. Normally, when the test is carried out at the manufacturer's works, the test supervisor is a staff member of the pump manufacturer.

During the tests all persons charged with effecting the measurements are subordinated to the chief of tests, who conducts and supervises the measurements, reports on test conditions and the results of the tests and then drafts the test report. All questions arising in connection with the measurements and their execution are subject to his decision.

The parties concerned shall provide all assistance that the chief of tests considers necessary.

5.2.5 State of pump

When tests are not carried out in the manufacturer's works, opportunity shall be allowed for preliminary adjustments by both manufacturer and installer.

5.2.6 Test programme

The programme and procedure to be followed in the test shall be prepared by the test supervisor and submitted to both manufacturer/supplier and purchaser in ample time for consideration and agreement.

Only the guaranteed operational data (see 4.1) shall form the basis of the test, other data determined by measurement during the tests shall have merely an indicative (informative) function and it shall be so stated if they are included in the programme.

5.2.7 Testing equipment

When deciding on the measuring procedure, the measuring and recording apparatus required shall be specified at the same time.

The test supervisor shall be responsible for checking the correct installation of the apparatus and its proper functioning.

All of the measuring apparatus shall be covered by reports showing by calibration or by comparison with other ISO or IEC standards that it complies with the requirement of 6.2. These reports shall be presented if required.

Guidance for suitable period between calibrations of test instruments is given in annex E.

5.2.8 Records

All test records and record charts shall be initialled by the test supervisor and by the representatives of both the manufacturer/supplier and purchaser if present, each of whom shall be provided with a copy of all records and charts.

The evaluation of the test results shall be made as far as possible while the tests are in progress and, in any case, before the installation and instrumentation are dismantled in order that suspect measurements can be repeated without delay.

5.2.9 Test report

After scrutiny, the test results shall be summarized in a report which is signed by the test supervisor alone, or together, by him and representatives of the manufacturer/supplier and of the purchaser.

All parties specified in the contract shall receive a copy of the report.

The test report should contain the following information:

- a) place and date of acceptance test;
- b) manufacturer's name, type of pump, serial number, and possibly year of construction;
- c) impeller diameter, blade angle or other impeller identifications;
- d) guaranteed characteristics, operational conditions during the acceptance test;
- e) specification of the pump's driver;
- f) sketch of test arrangement, diameters of measuring sections, description of the test procedure and the measuring apparatus used including calibration data;
- g) readings;
- h) evaluation and analysis of test results;
- i) conclusions:
 - comparison of the test results and the guaranteed quantities,
 - determination of action taken in connection with any special agreements that were made,
 - recommendation whether the pump can be accepted or should be rejected and under what conditions (if the guarantees are not fully satisfied the final decision whether the pump can be accepted or not is up to the purchaser),
 - statements arising out of action taken in connection with any special agreements that were made.

A pump test sheet is given for guidance in annex J.

5.3 Test arrangements

5.3.1 General

The conditions necessary to ensure satisfactory measurement of the characteristics of operation are defined in this subclause, taking into account the accuracy required for tests of grades 1 and 2.

NOTE 1 The performance of a pump in a given test arrangement, however accurately measured, cannot be assumed to be a correspondingly accurate indication of its performance in another arrangement.

NOTE 2 Recommendations and general guidance about suitable pipe arrangements to ensure satisfactory measurements are given in clauses 7 and 8 and, if necessary, they can be used in conjunction with the International Standards on measurement of flow rates in closed conduits concerning the different methods (see clause 7).

5.3.2 Standard test arrangements

The best measuring conditions are obtained when, in the measuring sections, the flow has

- an axially symmetrical velocity distribution;
- a uniform static pressure distribution;
- freedom from swirl induced by the installation.

For grades 1 and 2, verification is not required as it is not possible, in practice, entirely to meet these requirements.

It is possible to prevent a very poor velocity distribution or swirl by avoiding any bend or a combination of bends, any expansion or any discontinuity in the transverse profile in the vicinity (less than four diameters) of the measuring section.

Generally the effect of the inlet flow conditions increases with the type number K of the pump. When $K > 1,2$ it is recommended to simulate the site conditions.

It is recommended that for standard test arrangements leading from reservoirs with a free surface or from large stilling vessels in a closed circuit, the inlet straight length L shall be determined by the expression: $L/D = K + 5$, where D is the pipe diameter. This is especially valid for grade 1 tests.

This expression is also valid for an arrangement that includes, at a distance L upstream, a simple right-angle bend that is not fitted with guide vanes. Under these conditions, flow straighteners are not necessary in the pipe between the bend and the pump. However, in a closed circuit where there is neither a reservoir nor a stilling vessel immediately upstream of the pump, it is necessary to ensure that the flow into the pump is free from swirl induced by the installation and has a normal symmetrical velocity distribution.

Significant swirl can be avoided by

- careful design of the test circuit upstream of the measuring section;
- judicious use of a flow straightener;
- suitable arrangement of the pressure tapings to minimize their influence on the measurement.

It is recommended not to install a throttle valve in the suction pipe (see 5.4.4). Nevertheless, if this cannot be avoided, for instance for cavitation tests, the straight pipe length between the valve and the pump inlet should be in conformity with the requirements of 11.2.2.

5.3.3 Simulated test arrangements

When from the reasons given above it is agreed to test a pump under simulated site conditions, it is important that at the inlet of the simulated circuit the flow should as far as possible be free from significant swirl induced by the installation and have a symmetrical velocity distribution. All necessary provisions shall be made to ensure these conditions are achieved.

If necessary, for grade 1 tests the velocity distribution of the flow into the simulated circuit shall be determined by careful Pitot tube traverses, in order to establish that the required flow characteristics exist. If not, the required characteristics can be obtained by the installation of suitable means, such as a flow straightener, adapted to correct the fault in the flow (swirl or asymmetry). Specifications of the most widely used types of flow straighteners can be found in ISO 7194. But care shall be taken to ensure that the conditions of test will not be affected by the pressure losses associated with some straightening devices.

5.3.4 Pumps tested with fittings

If specified in the contract, standard tests can be carried out on a combination of a pump and the following:

- a) associated fittings at the final site installation; or
- b) an exact reproduction thereof; or
- c) fittings introduced for testing purposes and taken as forming part of the pump itself.

The flow at the inlet and outlet of the whole combination shall comply with the requirements specified in 5.3.2.

Measurements shall be taken in accordance with 8.2.2.

5.3.5 Pumping installation under submerged conditions

Where a pump, or a combination of a pump and its fittings, is tested or installed in conditions where the standard pipe connection as described in 5.3.2 cannot be made owing to inaccessibility or submergence, measurements shall be taken in accordance with 8.2.3.

5.3.6 Borehole and deep-well pumps

Borehole and deep-well pumps cannot usually be tested with their complete lengths of delivery main and, consequently, the loss of head in the portions omitted and the power absorbed by any shafting therein, cannot be taken into account. The thrust bearing will be more lightly loaded during the test than it would be in the final installation. The measurements shall be taken in accordance with 8.2.3.

5.3.7 Self-priming pumps

In principle, the priming ability of self-priming pumps shall always be verified at the contractual static suction head with the attached inlet piping equivalent to that in the final installation. When the test cannot be carried out in the described manner, the test arrangement to be used shall be specified in the contract.

5.4 Test conditions

5.4.1 Test procedure

The duration of the test shall be sufficient to obtain consistent results regarding the degree of accuracy to be achieved.

All measurements shall be made under steady conditions of operation or unsteady within the limits given in Table 4.

A decision to make measurements when such conditions cannot be obtained shall be a matter of agreement between the parties concerned.

Verification of the guarantee point shall be obtained by recording at least three (grade 2 tests) or five (grade 1 tests) points of measurements closely and evenly grouped around the guarantee point, for example between $0,9 Q_G$ and $1,1 Q_G$.

Where, for special reasons, it is necessary to determine performance over a range of operating conditions, a sufficient number of measurement points shall be taken to establish the performance within the limits of uncertainty stated in 6.2.

If the driving power available during a test on a test stand is insufficient, and if the test has to be carried out at reduced speed of rotation, the test results shall be translated to the specified speed of rotation in accordance with 6.1.2.

5.4.2 Stability of operation

5.4.2.1 General remarks

For the purposes of this International Standard, the following shall be considered.

- a) Fluctuations: short-period changes in the measured value of a physical quantity about its mean value during the time that a single reading is being made.
- b) Variations: those changes in value which take place between one reading and the next.

5.4.2.2 Permissible fluctuations in readings and use of damping

5.4.2.2.1 Direct visual observation of the signals delivered by measuring systems

For each quantity to be measured, Table 3 gives the permissible amplitude of fluctuations.

Where the construction or operation of a pump is such that fluctuations of great amplitude are present, measurements may be carried out by providing a damping device in the measuring instruments or their connecting lines which is capable of reducing the amplitude of the fluctuations to within the values given in Table 3.

Since it is possible that damping will significantly affect the accuracy of the readings, use shall be made of symmetrical and linear damping device, for example a capillary tube, which has to provide an integration over at least one complete cycle of fluctuations.

Table 3 — Permissible amplitude of fluctuations as a percentage of mean value of quantity being measured

Measured quantity	Permissible amplitude of fluctuations	
	grade 1 %	grade 2 %
Flow rate	± 3	± 6
Pump total head		
Torque		
Power input		
Speed of rotation	± 1	± 2
<p>When using a differential pressure device to measure flow rate, the permissible amplitude of the fluctuations of the observed differential pressure shall be ± 6 % for grade 1 and ± 12 % for grade 2.</p> <p>In the case of separate measurements of inlet total pressure and outlet total pressure, the maximum permissible amplitude of fluctuation shall be calculated on the pump total head.</p>		

5.4.2.2.2 Automatic recording or integration of signals delivered by measuring systems

When the signals delivered by the measuring systems are automatically recorded or integrated by the measuring device, the maximum permissible fluctuation amplitude of these signals may be higher than the value given in Table 3, if

- the measuring system used includes an integrating device carrying out automatically, with the required accuracy, the integration necessary to calculate the mean value over an integration period much longer than the response time of the corresponding system;
- the integration necessary to calculate the mean value may be carried out later on, from the continuous or sampled record of the analog signal $x(t)$. (The sampling conditions should be specified in the test report.)

5.4.2.3 Number of sets of observations

5.4.2.3.1 Steady conditions

Test conditions are called steady if the mean value of all quantities involved (rate of flow, pump total head, power input, torque and speed of rotation) are independent of time. In practice, test conditions may be regarded as steady if the variations of each quantity, observed at the test operating point for at least 10 s, do not exceed the values given in the upper part of Table 4. If this condition is met, and if the fluctuations are less than the permissible values given in Table 3, only one set of readings of individual quantities will be recorded for the test point considered.

5.4.2.3.2 Unsteady conditions

In such cases where the unsteadiness of test conditions gives rise to doubts concerning the accuracy of the tests, the following procedure shall be followed.

At each test point repeated readings of the measured quantities shall be made at random intervals of time, but not less than 10 s, only speed of rotation and temperature being allowed to be controlled. All settings of the throttle valve, water level, gland, balance water, etc. shall be left completely unaltered.

The difference between these repeated readings of the same quantities will be a measure of the unsteadiness of the test conditions, which are at least partly influenced by the pump under test as well as by the installation.

A minimum of three sets of readings shall be taken at each test point, and the value of each separate reading and of the efficiency derived from each set of readings shall be recorded. The percentage difference between the largest and smallest values of each quantity shall not be greater than that given in Table 4. It should be noted that a wider difference is permitted if the number of readings is increased (see Table 4).

Table 4 — Limits of variations between repeated measurements of the same quantity
(based on 95 % confidence limits)

Conditions	Number of sets of readings	Permissible difference between largest and smallest readings of each quantity, related to the mean value			
		Flow rate, pump total head, torque, power input		Speed of rotation	
		grade 1 %	grade 2 %	grade 1 %	grade 2 %
Steady	1	0,6	1,2	0,2	0,4
Unsteady	3	0,8	1,8	0,3	0,6
	5	1,6	3,5	0,5	1,0
	7	2,2	4,5	0,7	1,4
	9	2,8	5,8	0,8	1,6
	13	2,9	5,9	0,9	1,8
	> 20	3,0	6,0	1,0	2,0

These maximum permissible differences are designed to ensure that the uncertainties due to scatter, taken together with the systematic uncertainties given in Table 7, will result in overall measurement uncertainties not greater than those given in Table 8.

The arithmetic mean of all the readings for each quantity shall be taken as the actual value for the purposes of the test.

If the values given in Table 4 cannot be reached, the cause shall be ascertained, the conditions rectified and a new complete set of readings made, i.e. all the readings in the original set shall be rejected. No reading or selection of readings in the set of observations may be rejected because it lies outside the limits.

In the case where the excessive variation is not due to procedure or instrumentation errors, and cannot therefore be eliminated, the limits of error may be calculated by statistical analysis.

5.4.3 Speed of rotation during test

Unless otherwise agreed, tests may be carried out at a test speed of rotation within the range 50 % to 120 % of the specified speed of rotation to establish the flow rate, pump total head and power input. However, it should be noted that when departing by more than 20 % from the specified speed of rotation the efficiency may be affected.

For NPSH tests, the test speed of rotation should lie within the range 80 % to 120 % of the specified speed of rotation, provided that the rate of flow lies within 50 % and 120 % of the rate of flow corresponding to the maximum efficiency at the test speed of rotation.

NOTE For tests conforming to the requirements of 11.1.2.1 and 11.1.2.2, the above-mentioned variation may always be allowed. For tests conforming to the requirements of 11.1.2.3 it may be allowed for pumps with type number *K* less than or equal to 2; for pumps with type number *K* greater than 2, agreement should be reached between the parties concerned.

5.4.4 Setting pump total head

The test conditions may be obtained, among other methods, by throttling in either or both the inlet and outlet pipes. When throttling in the inlet pipe is used, due consideration shall be given to the possibility of cavitation or of air coming out of the water, which might affect the operation of the pump, the flow measuring device or both (see 11.2.2).

5.4.5 Test on pumps for liquids other than clean cold water

5.4.5.1 General

The performance of a pump varies substantially with the nature of the liquid being pumped. Although it is not possible to give general rules whereby performance with clean cold water can be used to predict performance on another liquid, it is often desirable for the parties to agree on empirical rules to suit the particular circumstances and test the pump with clean cold water.

Annexes G and H may be considered as a guide.

5.4.5.2 Characteristics of "clean cold water"

The characteristics of the water corresponding to what is called in this International Standard "clean cold water" shall be within the limits indicated in Table 5.

Table 5 — Specification of "clean cold water"

Characteristics	Unit	max.
Temperature	°C	40
Kinematic viscosity	m ² /s	1,75 × 10 ⁻⁶
Density	kg/m ³	1050
Non-absorbent free solid content	kg/m ³	2,5
Dissolved solid content	kg/m ³	50

The total dissolved and free gas content of the water shall not exceed the saturation volume corresponding

- for an open circuit, to the pressure and temperature in the pump sump;
- for a closed loop, to those existing in the tank.

5.4.5.3 Characteristics of liquids for which clean cold water tests are acceptable

Pumps for liquids other than clean cold water may be tested for head and for flow rate and efficiency with clean cold water if the liquid is within the specifications in Table 6²⁾.

Table 6 — Characteristics of liquids

Characteristics of liquids	Unit	min.	max.
Kinematic viscosity	m ² /s	no limit	10 × 10 ⁻⁶
Density	kg/m ³	450	2000
Non-absorbent free solids content	kg/m ³	—	5,0

2) The usual NPSHR curves of pump manufacturers are established using clean cold water and the NPSHR values are always given for clean cold water.

The total dissolved and free gas content of the liquid shall not exceed the saturation volume corresponding

- for an open circuit, to the pressure and temperature in the pump sump;
- for a closed loop, to those existing in the tank.

Tests on pumps for liquids other than those specified above shall be subject to special agreement.

In the absence of a special agreement, cavitation tests shall be carried out with clean cold water. Attention is drawn to the fact that the results may be affected by this procedure when the liquid to be pumped is not clean cold water.

6 Analysis of test results

6.1 Translation of the test results to the guarantee conditions

6.1.1 General

The quantities required to verify the characteristics guaranteed by the manufacturer/supplier and given in 4.1 are generally measured under conditions more or less different from those on which the guarantee is based.

In order to determine whether the guarantee would have been fulfilled if the tests had been conducted under the guarantee conditions, it is necessary to translate the quantities measured under different conditions to those measured under guarantee conditions.

6.1.2 Translation of the test results into data based on the specified speed of rotation (or frequency) and density

All test data obtained at the speed of rotation n in deviation from the specified speed of rotation n_{sp} shall be translated to the basis of the specified speed of rotation n_{sp} .

If the deviation from the test speed of rotation n to the specified speed of rotation n_{sp} does not exceed the permissible variations stated in 5.4.3, and if the deviation of the test liquid from the specified liquid is within the limits stated in 5.4.5.3, the measured data on the rate of flow Q , the pump total head H , the power input P , and the pump efficiency η can be converted by means of the equations:

$$Q_T = Q \frac{n_{sp}}{n}$$

$$H_T = H \left(\frac{n_{sp}}{n} \right)^2$$

$$P_T = P \left(\frac{n_{sp}}{n} \right)^3 \cdot \frac{\rho_{sp}}{\rho}$$

$$\eta_T = \eta$$

and the results obtained for the NPSHR can be converted by means of the equation

$$(\text{NPSHR})_T = (\text{NPSHR}) \left(\frac{n_{sp}}{n} \right)^x$$

As a first approximation for the NPSH, the value $x = 2$ may be used if the specified conditions given in 5.4.3 for the speed of rotation and the rate of flow have been fulfilled and if the physical state of the liquid at the impeller inlet is such that no gas separation can affect the operation of the pump. If the pump operates near its cavitation limits, or if the deviation of the test speed from the specified speed exceeds the specifications given in 5.4.3, the phenomena may be influenced by, for example, thermodynamic effects, the variation of the surface tension, or the differences in

dissolved or occluded air content. Values of exponent x between 1,3 and 2 have been observed and an agreement between the parties is mandatory to establish the conversion formula to be used.

In the case of combined motor pump units or when the guarantees are with respect to an agreed frequency and voltage instead of an agreed speed of rotation (see 4.1), the flow rate, pump total head, power input, and efficiency data are subject to the above-mentioned translation laws, provided that n_{sp} is replaced by the frequency f_{sp} and n by the frequency f . Such translation, however, shall be restricted to cases where the selected frequency during the test varies by no more than 1 %. If the voltage used in the test is no more than 5 % above or below the voltage on which the guaranteed characteristics are based, the other operational data require no change.

If the above-mentioned deviations, i.e. ± 1 % for frequency and ± 5 % for voltage, are exceeded, it will be necessary for the purchaser and the manufacturer/supplier to arrive at an agreement.

6.1.3 Test made with an NPSHA different from that guaranteed

Pump performance at a high NPSHA cannot be accepted, after correction for speed of rotation within the permitted ranges in 5.4.3, to indicate performance at a lower NPSHA.

However, pump performance at a low NPSHA can be accepted, after correction for speed of rotation within the permitted ranges given in 5.4.3, to indicate performance at a higher NPSHA, provided that the absence of cavitation has been checked in accordance with 11.1.2.2 or 11.1.2.3.

6.2 Measuring uncertainties

6.2.1 General

Every measurement is inevitably subject to uncertainty, even if the measuring procedure and the instruments used, as well as the methods of analysis fully comply with the existing rules and especially with the requirements of this International Standard.

6.2.2 Determination of random uncertainty

For the purposes of this International Standard, the random uncertainty on the measurement of a variable is taken as twice the standard deviation of this variable. The uncertainty can be calculated and indicated as such for any measurement in accordance with ISO 5198.

When partial errors (the combination of which gives the uncertainty) are independent of each other, are small and numerous and have a Gaussian distribution, there is 95 % probability that the true error (i.e. the difference between the measured value and the true value) is less than the uncertainty.

6.2.3 Maximum permissible systematic uncertainty

The uncertainty of a measurement depends partly on the residual uncertainty in the instrument or in the method of measurement used. After all known errors have been removed by calibration, careful measurement of dimensions, proper installation etc. it remains an error which never disappears and cannot be reduced by repeating the measurements if the same instrument and the same method of measurement are used. This component of the error is called "systematic uncertainty".

Clauses 7 through 11 describe different methods of measurement and devices to be used to determine the flow rate, pump total head, speed of rotation, pump power input, and NPSHR value in the range of accuracy required for tests according to grades 1 and 2.

Devices or methods which are known by calibration or references to other standards to result in a measurement with a systematic uncertainty not exceeding the maximum permissible values given in Table 7 may be used. These instruments or methods shall be accepted by the parties concerned.

Table 7 — Permissible values of systematic uncertainties

Quantity	Permissible value	
	grade 1 %	grade 2 %
Flow rate	± 1,5	± 2,5
Speed of rotation	± 0,35	± 1,4
Torque	± 0,9	± 2,0
Pump total head	± 1,0	± 2,5
Driver power input	± 1,0	± 2,0

6.2.4 Overall measurement uncertainty

The random uncertainty due either to the characteristics of the measuring system or to variations of the measured quantity or both appears directly as a scatter of the measurements. Unlike the systematic uncertainty, the random uncertainty can be reduced by increasing the number of measurements of the same quantity under the same conditions.

The overall measurement uncertainty is to be calculated by the square root of the sum of the squares of the systematic and random uncertainties.

The overall measurement uncertainties shall as far as possible, be determined after the test taking into account the measurement and operation conditions pertaining to the test.

If the recommendations relating to the systematic uncertainty, as given in 6.2.3, and all the requirements relating to the test procedure as given in this International Standard are complied with, it may be assumed that the overall uncertainty (at 95 % confidence level) will not exceed the values given in Table 8.

Table 8 — Permissible values of overall measurement uncertainties

Quantity	Symbol	Grade 1	Grade 2
		%	%
Flow rate	e_Q	± 2,0	± 3,5
Speed of rotation	e_n	± 0,5	± 2,0
Torque	e_T	± 1,4	± 3,0
Pump total head	e_H	± 1,5	± 5,5
Driver power input	e_{Pgr}		
Pump power input (computed from torque and speed of rotation)	e_P		
Pump power input (computed from driver power and motor efficiency)	e_P	± 2,0	± 4,0

6.2.5 Determination of measurement uncertainty in efficiency

The overall uncertainty in the overall efficiency and in the pump efficiency are to be calculated by the following formulae

$$e_{ngr} = \sqrt{e_Q^2 + e_H^2 + e_{Pgr}^2}$$

$$e_\eta = \sqrt{e_Q^2 + e_H^2 + e_T^2 + e_n^2} \quad (\text{if efficiency is computed from torque and speed of rotation})$$

$$e_\eta = \sqrt{e_Q^2 + e_H^2 + e_P^2} \quad (\text{if efficiency is computed from pump power input})$$

Using the values given in Table 8, the calculations lead to the results given in Table 9.

Table 9 — Resulting values of the overall uncertainties of efficiency

Quantity	Symbol	Grade 1	Grade 2
		%	%
Overall efficiency (computed from Q , H and P_{gr})	e_{ngr}	± 2,9	± 6,1
Pump efficiency (computed from Q , H , T and n)	e_{η}	± 2,9	± 6,1
Pump efficiency (computed from Q , H , P_{gr} and η_{mot})	e_{η}	± 3,2	± 6,4
NOTE For taking into account additional uncertainties referred to, losses refer to 10.4.			

The uncertainties as given in Tables 8 and 9 indicate the possible deviations of the value of a quantity found by measurement from its true value.

6.3 Values of tolerance factors

Because of manufacturing uncertainties during completion, geometrical deviations from the drawings are given at every pump.

When comparing the test results with guaranteed values (operation points), tolerances shall be allowed, including the possible deviations in operating dates between the tested pump and a pump without any manufacturing uncertainties.

It should be pointed out that these tolerances in operating behaviour of the pump are relative to the real pump and not to the test conditions and the measuring uncertainties.

To simplify the verification of guaranteed values, the introduction of tolerance factors is recommended.

These tolerance factors, $\pm t_Q$, $\pm t_H$ and t_{η} on the flow rate, pump total head and pump efficiency, respectively, shall be applied to the guarantee point Q_G , H_G .

In the absence of a specific agreement on the values to be used, the values given in Table 10 shall be used.

Table 10 — Values of tolerance factors

Quantity	Symbol	Grade 1	Grade 2
		%	%
Flow rate	t_Q	± 4,5	± 8
Pump total head	t_H	± 3	± 5
Pump efficiency	t_{η}	- 3	- 5

Other tolerance ranges (e.g. only given by positive tolerance factors) may be agreed in the contract.

The performance of pumps produced in series and with selection made from typical performance curves published in catalogues and pumps with a power input less than 10 kW may vary. Tolerance factors for those pumps are indicated in annex A.

6.4 Verification of guarantees

6.4.1 General

The verification of each guarantee shall be accomplished by comparing the results obtained from the tests with the values guaranteed in the contract (including their associated tolerances).

6.4.2 Verification of guaranteed flow rate, head and efficiency

The results of measurements shall be translated to the specified speed (or frequency) according to 6.1.2. They shall then be plotted against the flow rate, Q . Curves of best fit to the measured points will represent the performance of the pump.

A tolerance cross with the horizontal line $\pm t_Q \cdot Q_G$ and the vertical line $\pm t_H \cdot H_G$ is drawn through the guarantee point Q_G, H_G .

The guarantee on the head and flow rate have been met if the $H(Q)$ -curve cuts or at least touches the vertical and/or horizontal line (see Figure 2).

The efficiency shall be derived from the measured $H(Q)$ -curve where it is intersected by the straight line passing through the specified duty point Q_G, H_G and the zero of the QH -axes and from where a vertical line intersects the $\eta(Q)$ -curve.

The guarantee condition on efficiency is within tolerance if the efficiency value at this point of intersection is higher than or at least equal to $\eta_G (1 - t_\eta)$ (see Figure 2).

NOTE If the measured values of Q and H are larger than the guaranteed values Q_G and H_G but within the tolerances $Q_G + (t_Q \cdot Q_G)$ and also the efficiency is within tolerance, the actual power input may be higher than that assumed in the data sheet.

6.4.3 Verification of guaranteed NPSH

For checking the effect of cavitation and the value of the guaranteed NPSHR, the requirements given in 11.1 shall be complied with.

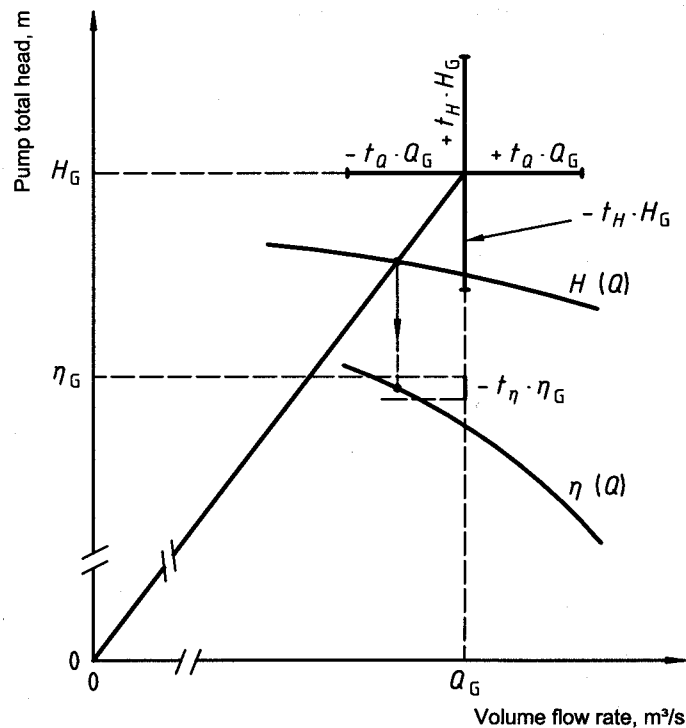

Figure 2 — Verification of guarantee on flow rate, head and efficiency

6.5 Obtaining specified characteristics

6.5.1 Reduction of impeller diameter

When it appears from the tests that the characteristics of the pump are higher than the specified characteristics, a reduction of the impeller diameter is generally carried out.

If the difference between the specified values and the measured values is small, it is possible to avoid a new series of tests by applying proportionality rules which allow the evaluation of the new characteristics.

The application of this method and the practical conditions for reducing the impeller diameter shall be the subject of a mutual agreement.

Annex B of this International Standard gives some indications which may be applied when the reduction of the mean outlet diameter of the impeller does not exceed 5 % for pumps of type number $K \leq 1,5$.

6.5.2 Speed variation

If a pump with a variable speed drive fails to meet or exceeds the guarantees, the test points may be recalculated for a different speed of rotation, provided that the maximum allowable continuous speed of rotation is not exceeded. In the absence of a specific agreement, the maximum permitted speed of rotation may be taken as equal to $1,02 n_{sp}$. In such cases, a new test is not required.

7 Measurement of flow rate

7.1 Measurement by weighing

ISO 4185 indicates all necessary information for the measurement of the liquid flow rate by the weighing method.

The weighing method, which gives only the value of the average flow rate during the time taken to fill the weighing tank, may be considered the most accurate method of flow rate measurement. It is affected by errors relating to weighing, to measuring the filling time, to the determination of the density taking into account the temperature of the fluid, and also there may be errors in connection either with diverting the flow (static method) or with dynamic phenomena at the time of weighing (dynamic method).

7.2 Volumetric method

ISO 8316 indicates all necessary information for the measurement of the liquid flow rate by the volumetric method.

The volumetric method approaches the accuracy of the weighing method and, similarly, only supplies the value of the average flow rate during the time it takes to fill the gauged capacity.

The calibration of the reservoir may be obtained by measuring the water level after successive volumes of water, determined either by mass or by means of a gauged pipette, are poured into the reservoir tank.

The volumetric method is affected by the errors relating to the calibration of the tank, the measurement of the levels, the measurement of filling time and also by errors in connection with diverting the flow. Moreover, the watertightness of the reservoir shall be checked and a leakage correction made if necessary.

However, there exists a variant of the volumetric method which can be used on-site and for larger flow rates, where one can use, as the gauged capacity, a natural reservoir, the volume of which has been determined by geometrical or topographic procedures. A guide on the use of this method will be given in the revised version of IEC 60041. It shall, however, be emphasized that the accuracy of this method is much less on account of the difficulty in measuring the levels which might be neither steady nor uniform.

7.3 Differential pressure devices

The construction, installation and use of orifice plates, nozzles and Venturi tubes are the subject of ISO 5167-1, whilst ISO 2186 gives specifications on connecting piping for the manometer.

Attention should particularly be drawn to the minimum straight lengths to be adhered to upstream of the differential pressure device; these are specified in ISO 5167-1 for various configurations of piping. If it is necessary to place the differential pressure device downstream of the pump (which is not covered in the tables referred to); the pump may be considered for the purposes of this International Standard to create a disturbance in the flow equivalent to a single 90° bend either in the same plane as the pump volute or the last stage of a multistage pump or the outlet branch of the pump.

It should also be noted that the diameter of the pipe and the Reynolds number shall fall within the ranges specified in ISO 5167-1 for each type of device.

It shall be assured that the flow measuring apparatus is not influenced by cavitation or degassing which can occur, for example, at a control valve. The presence of air can usually be detected by operating the air vents on the measuring device.

It shall be possible to check the differential pressure measurement apparatus by comparison with a liquid column manometer or a dead-weight manometer, or with other pressure calibration standards.

If all the requirements of the relevant standards are met, the discharge coefficients given in the standards can be used without calibration.

7.4 Thin-plate weirs

The specifications for the construction, installation and utilisation of rectangular or triangular thin-plate weirs are given in ISO 1438-1. ISO 4373 specifies the level measuring device.

Particular attention is to be drawn to the great sensitivity of these devices to the upstream flow conditions and thus to the necessity to comply with the requirements for the approach channel.

For the application of this International Standard, the smallest scale division of all instruments used for the measurement of the head over the weir shall not be more than that corresponding to 1,5 % of the flow rate to be measured.

7.5 Velocity area methods

These methods are the subject of ISO 3354 and ISO 3966, which deal with discharge measurements in closed conduits by means of current meters and Pitot static tubes, respectively. These standards give all the necessary specifications concerning conditions of application, choice and operation of the apparatus, measurement of local velocities and calculation of the flow rate by integration of the velocity distribution.

The complication of these methods does not justify their use for grade 2 tests, but they are sometimes the only ones that can be applied when testing pumps with large flow rates for grade 1 tests.

Except in very long pipe installations, it is preferable that the measuring section be placed upstream of the pump in order to avoid too much turbulence or swirling flow.

7.6 Tracers methods

These methods, applied to the measurement of the flow rate in the pipes, are the subject of ISO 2975, the different parts of which cover both the dilution method (constant rate injection) and the transit time method, each method using either radioactive or chemical tracers.

As for the velocity area methods, the tracer methods are justified only for grade 1 tests. They should only be used by specialized staff and it should be noted that the use of radioactive tracers is subject to certain constraints.

7.7 Other methods

Some apparatus such as turbines, electromagnetic (ISO 9104) or even ultrasonic, vortex or variable-area flowmeters, may be used, provided they are calibrated beforehand by means of one of the primary methods described in 7.1 or 7.2. When installed permanently on a test facility, the possibility of a periodic check of their calibration shall be taken into account.

The calibration shall bear on the whole of the flowmeter and the associated measuring system. The calibration should normally be carried out under the actual operating conditions (pressure, temperature, water quality, etc.) prevailing during the tests. Attention shall be paid to ensure that the flowmeter is not affected by cavitation during the tests.

Turbine and electromagnetic flowmeters do not require very long upstream straight pipe lengths (a length of five times the pipe diameter is in most cases sufficient) and achieve a very good accuracy. Ultrasonic flowmeters are very sensitive to the velocity distribution and shall be calibrated under the actual conditions of operation. The use of variable area flowmeters should be restricted to grade 2 tests.

8 Measurement of pump total head

8.1 General

8.1.1 Measurement principles

The pump total head is calculated in accordance with its definition (3.19). Expressed as a height of pumped liquid column, it represents the energy transmitted by the pump per unit weight of liquid.

The concept of head may be replaced by that of specific energy ($y = gH$, see 3.20) which represents the energy transmitted by the pump per unit mass of liquid; although less usual, its use is to be recommended.

The various quantities specified in the definition of pump total head in 3.19 should as a rule be determined in the inlet section S_1 and the outlet section S_2 of the pump (or of the pump set and fittings which is the subject of the tests). In practice, for convenience and measurement accuracy, the measurements are generally carried out in cross-sections S_1' and S_2' some way upstream from S_1 and downstream from S_2 (Figure 3). Thus, account shall be taken of the friction losses in the pipe, i.e. H_{J1} between S_1' and S_1 and H_{J2} between S_2 and S_2' (and possibly of the local head losses), and the pump total head is given by

$$H = H_2' - H_1' + H_{J1} + H_{J2}$$

where H_1' and H_2' are the total head at S_1' and S_2' .

Subclause 8.2 defines the measuring sections in various types of installations and a method of estimating the head losses.

8.1.2 Various measurement methods

Depending on the installation conditions of the pump and on the layout of the circuit, the pump total head may be determined either by measuring separately the inlet and outlet total heads, or by measuring the differential pressure between inlet and outlet and adding the difference in velocity head if any (see Figure 10).

Total heads may also be deduced either from pressure measurements in conduits or from water level measurements in basins. For these cases, subclauses 8.2 to 8.4 deal with the selection and arrangement of the measuring section, the various measuring devices which can be used, and the determination of the velocity head.

8.1.3 Uncertainty of measurement

The uncertainty of the pump total head measurement shall be obtained by combining the estimated uncertainties of each term of which it is composed; thus the manner of conducting this calculation depends on the measurement methods used and it is only possible to give some general information for the various errors involved, as follows.

- a) The errors in terms of height are generally negligible in comparison with other sources of error.
- b) The errors in terms of velocity head arise on the one hand from the errors made in measurement of the flow rate and in measuring the section area, and on the other hand from the fact that taking $U^2/2g$ as an evaluation of the mean velocity head is only an approximation which becomes more accurate as the velocity distribution becomes more uniform. These errors can reach a significant importance, in relative value, for low total head pumps.
- c) The errors in level or pressure measurements shall be evaluated in each particular case by giving consideration not only to the type of apparatus used but also to the conditions of use (quality of the pressure tappings, water-tightness of the connecting pipes, etc.) and to the characteristics of the flow (unsteadiness, fluctuations, pressure distribution, etc.).

8.2 Definition of the measuring sections

8.2.1 Pump tested on a standardized installation

8.2.1.1 Inlet measuring section

When a pump is tested in a standard test arrangement as described in 5.3.2, the inlet measuring section shall normally be located at a distance of two diameters upstream from the pump inlet flange, when the length of the inlet pipe allows this. Should this length not be available (for instance in the case of a short bellmouth), in the absence of a prior agreement, the available straight length should be divided so as to take the best possible advantage of the local conditions upstream and downstream of the measuring section (for instance in the ratio 2 upstream to 1 downstream).

The inlet measuring section should be located in a straight section of pipe of the same diameter and coaxial with the pump inlet flange, so that the flow conditions are as close as possible to those recommended in 5.3.2. If a bend is present a short distance upstream of the measuring section, and if only one or two pressure tapings are in use (grade 2 tests), these should be perpendicular to the plane of the bend. See Figure 3 and 4.

For grade 2 tests, if the ratio of the inlet velocity head to the pump total head is very low (less than 0,5 %) and if the knowledge of the inlet total head itself is not very important (this is not the case for NPSH tests), it may be sufficient that the pressure tapping (see 8.4.1) be located on the inlet flange itself and not at two diameters upstream.

The inlet total head is derived from the measured gauge head, from the height of the measuring point above the reference plane and from the velocity head calculated as if a uniform velocity distribution prevailed in the suction pipe.

Errors in the measurement of pump inlet head can occur at partial flow due to pre-swirl. These errors can be detected and should be corrected as follows.

- a) If the pump draws from a free surface reservoir where the water level and the pressure acting on it are constant, the head loss between the reservoir and the inlet measuring section, in the absence of pre-swirl, follows a square law with flow rate. The value of the inlet total head should follow the same law. When the effects of pre-swirl lead to a departure from this relationship at low flow rates, the measured inlet total head should be corrected to take this difference into account (see Figure 5).
- b) If the pump does not draw from a reservoir with a constant level and pressure, another measuring section shall be selected sufficiently far upstream where the pre-swirl is known to be absent and it is then possible to predict the head losses between the two sections (but not directly about the inlet total head) in the same way as above. See Figures 3 and 4.

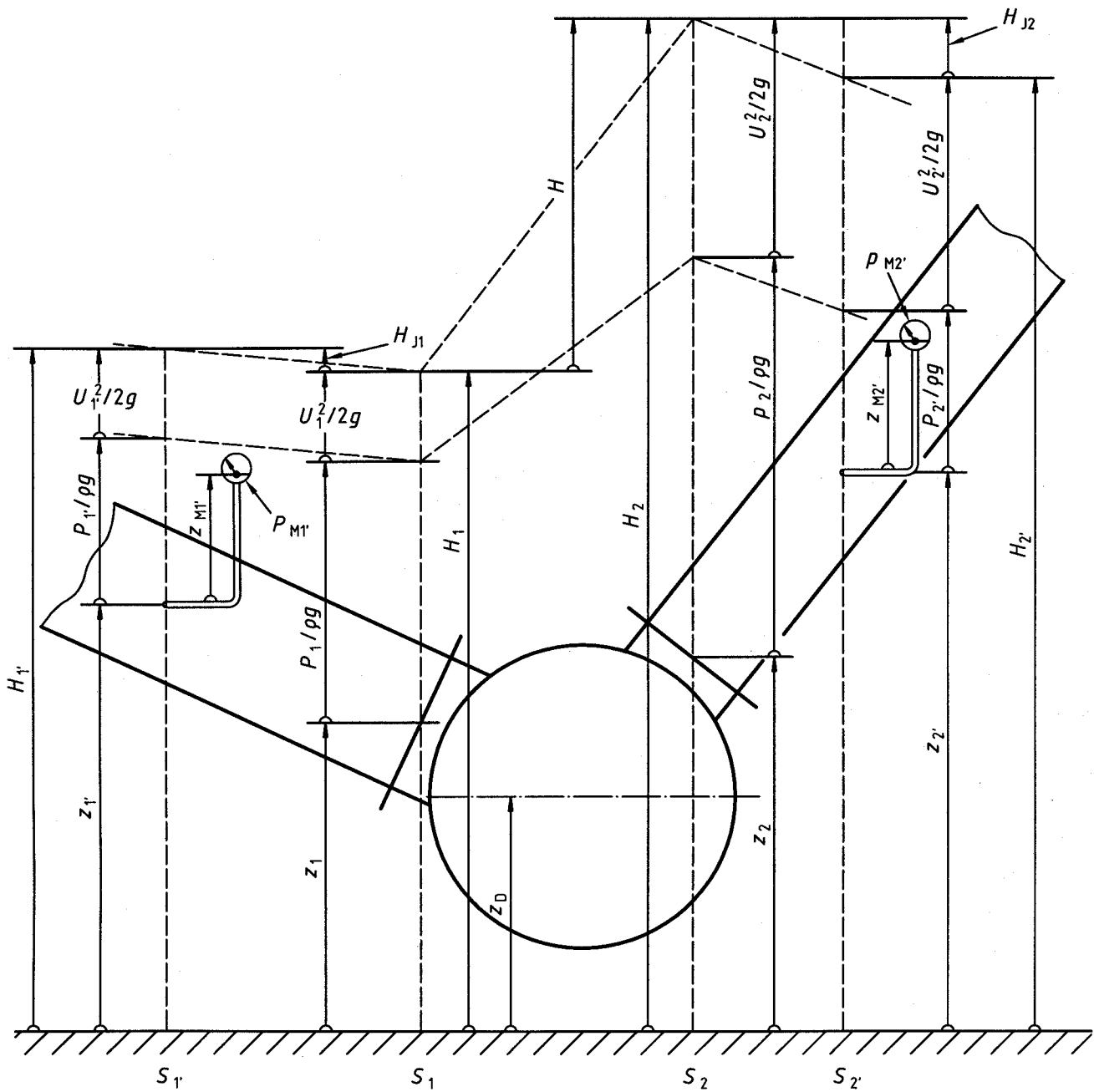

$$H = H_2 - H_1$$

$$H = z_2 - z_1 + \frac{p_2 - p_1}{\rho \cdot g} + \frac{U_2^2 - U_1^2}{2g}$$

$$H = z_2' - z_1' + z_{M2'} - z_{M1'} + \frac{p_{M2'} - p_{M1'}}{\rho \cdot g} + \frac{U_2^2 - U_1^2}{2g} + H_{J2} + H_{J1}$$

NOTE 1 The inclined position of the pump is to show that z_1 and z_1' or z_2 and z_2' respectively, may be different, which implies a difference of the corresponding pressure.

NOTE 2 The drawing shows only the principle and not technical details.

Figure 3 — Determination of pump total head

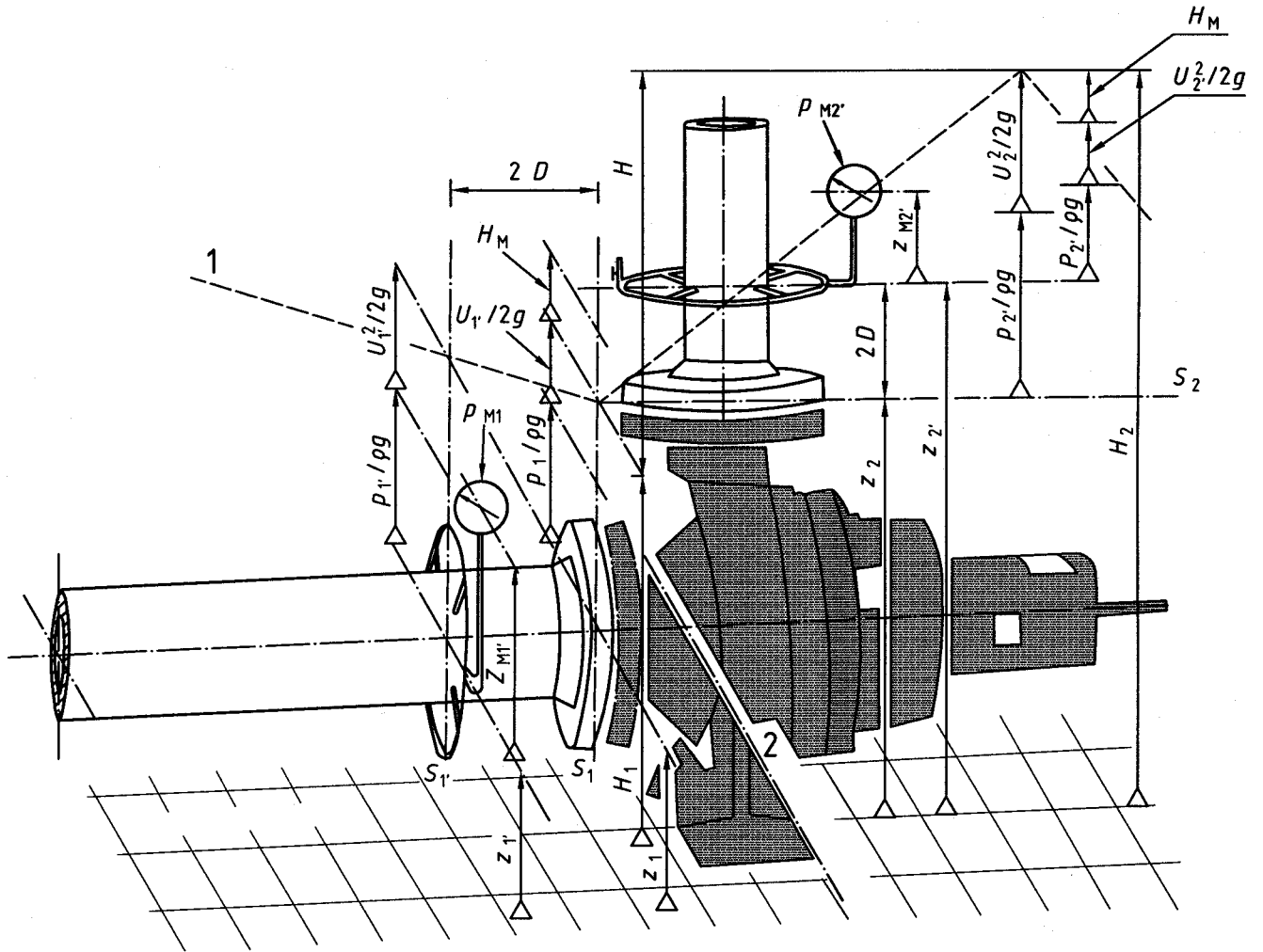

Key

1 Line of total head (total energy)

NOTE In this case for a horizontal shaft, $z_1 = z_D = z_1'$

Figure 4 — Isometric illustration of the determination of pump total head

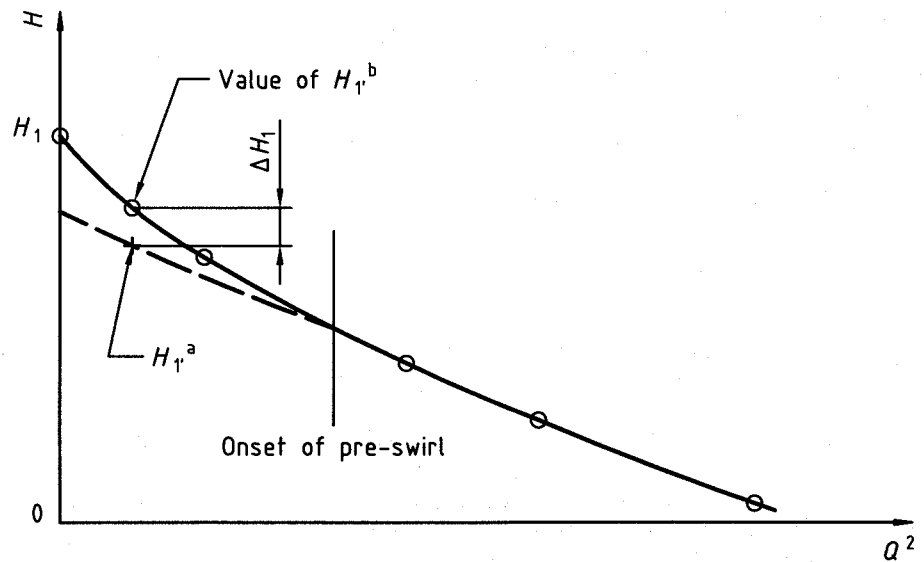

a Real value

b Affected by pre-swirl

Figure 5 — Correction of inlet total head

8.2.1.2 Outlet measuring section

The outlet measuring section shall normally be located at a distance of two diameters from the pump outlet flange. For pumps with outlet velocity head smaller than 5 % of the pump total head, the outlet measuring section for grade 2 tests may be located at the outlet flange.

The outlet measuring section should be arranged in a straight section of pipe coaxial with the pump outlet flange and of the same diameter. When only one or two pressure tapings are used (grade 2 tests), the pressure tapings should be perpendicular to the plane of the volute or of any bend existing in the pump casing (see Figure 6).

The outlet total head is derived from the measured gauge head, from the height of the measuring point above the reference plane, and from the velocity head calculated as if a uniform velocity distribution prevailed in the discharge pipe. The determination of the total head may be influenced by a swirl of the flow induced by the pump or by an irregular velocity or pressure distribution. The pressure tapping can then be located at a greater distance downstream. The head losses between the outlet flange and the measuring section shall be taken into account (see 8.2.4).

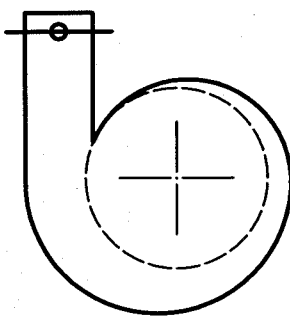

Figure 6 — Pressure tapping perpendicular to the plane of the volute or to the plane of a bend

8.2.2 Pump tested with fittings

If the tests are on the combination of the pump and the whole or part of its upstream and downstream connecting fittings, these being considered an integral part of the pump, the provision of 8.2.1 apply to the inlet and outlet flanges of the fittings instead of the inlet and outlet flanges of the pump. This procedure debits against the pump all head losses caused by the fittings.

Nevertheless, if the guarantee is on the performance of the pump only, the friction head losses and possibly local head losses between the inlet total head measuring section and the inlet flange, H_{J1} , and between the outlet flange and the outlet total head measuring section, H_{J2} , shall be determined in accordance with the method described in 8.2.4 and taken into account in the calculation of the pump total head.

The same applies if the fittings are part of the facility and thus are not part of the pump.

8.2.3 Submerged pumps and deep well pumps

Pumps of this type cannot be tested in standard arrangements as described in 5.3.2; their installation conditions are shown schematically in Figure 7.

The inlet total head is equal to the height above the reference plane of the free surface level of the liquid from which the pump draws, plus the head equivalent to the gauge pressure prevailing above this surface.

According to the circumstances, the outlet total head can be determined either by a pressure measurement in the discharge pipe (see 8.2.1.2) or, if the pump discharges into a free surface basin, by a level measurement in this basin. In this case, and provided that the liquid is really at rest near the level measuring point, the outlet head is equal to the height above the reference plane of the free surface level of the liquid in which the pump discharges plus the head equivalent to the gauge pressure prevailing above this surface.

This procedure debits against the pump all the head losses arising between the measuring sections.

If necessary, the friction head losses between the measuring sections and the contractual limits of the pump can be determined in accordance with the method described in 8.2.4. The local head losses due to the singularities of the circuit and to various fittings (suction filter, non-return valve, delivery elbow, valve, expanders, etc.) shall as far as possible be specified when drafting the contract, by the party which provides these fittings. If this appears impossible, the purchaser and the manufacturer/supplier shall agree the value to be adopted before the acceptance tests.

As deep well pumps [Figure 7a)] are generally not tested with their whole vertical pipes, unless the acceptance test is carried out on site, the friction head losses in the missing parts shall be evaluated and specified to the purchaser by the manufacturer/supplier. If it appears necessary to verify the specified characteristics by an on-site test, this shall be specified in the contract.

For tests of pumps of this kind, the guarantees may or may not apply also to the fittings.

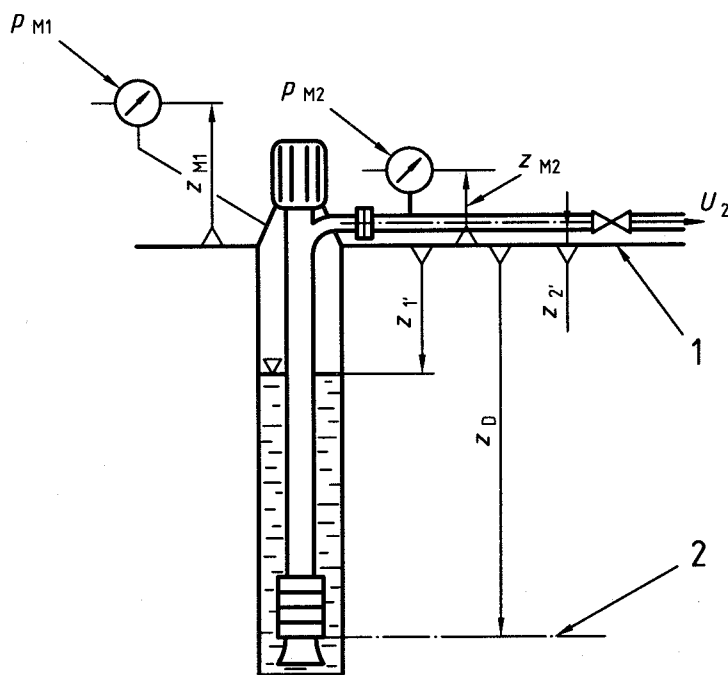

Key
 1 Reference plane
 2 NPSH datum plane

$$H_1 = z_1' + \frac{p_{M1}}{\rho g} + \frac{\rho_{f1}}{\rho} (z_{M1} - z_1')$$

$$H_2 = z_2' + \frac{p_{M2}}{\rho g} + \frac{\rho_{f2}}{\rho} (z_{M2} - z_2') + \frac{U_2^2}{2g}$$

$$H = z_2' - z_1' + \frac{p_{M2} - p_{M1}}{\rho g} + \frac{\rho_{f2}(z_{M2} - z_2') - \rho_{f1}(z_{M1} - z_1')}{\rho} + \frac{U_2^2}{2g}$$

a)

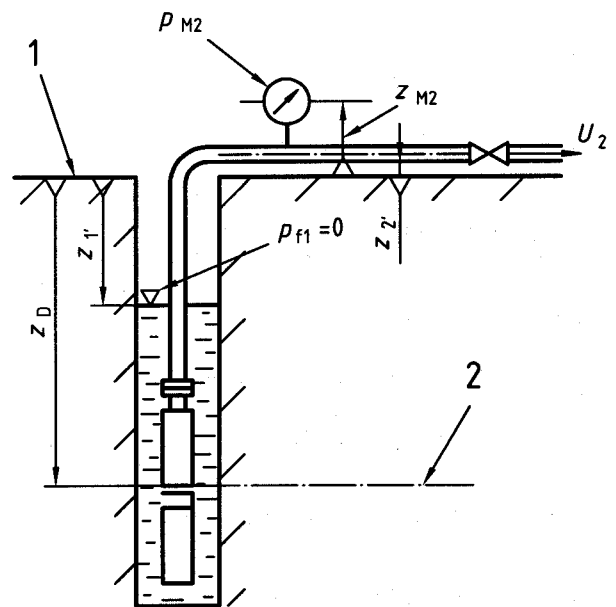

Key
 1 Reference plane
 2 NPSH datum plane

$$H_1 = z_1'$$

$$H_2 = z_2' + \frac{p_{M2}}{\rho g} + \frac{\rho_{f2}}{\rho} (z_{M2} - z_2') + \frac{U_2^2}{2g}$$

$$H = z_2' - z_1' + \frac{p_{M2}}{\rho g} + \frac{\rho_{f2}}{\rho} (z_{M2} - z_2') + \frac{U_2^2}{2g}$$

b)

Figure 7 — Measurement of pump total head H for various types of submerged pumps

8.2.4 Friction losses at inlet and outlet

The guarantees under 4.1 refer to the pump inlet and outlet flanges, and the pressure measuring points are in general at a distance from these flanges (see 8.2.1 through 8.2.3). It may therefore be necessary to add to the measured pump total head the head losses due to friction (H_{J1} and H_{J2}) between the measuring points and the pump flanges.

Such a correction should be applied only if

$$H_{J1} + H_{J2} \geq 0,005 H \text{ for grade 2 or}$$

$$H_{J1} + H_{J2} \geq 0,002 H \text{ for grade 1.}$$

If the pipe between the measuring points and the flanges is unobstructed, straight, of constant circular cross-section, and of length L then:

$$H_J = \lambda \frac{L}{D} \frac{U^2}{2g}$$

The value of λ should be derived from:

$$\frac{1}{\sqrt{\lambda}} = -2 \log_{10} \left[\frac{2,51}{Re \sqrt{\lambda}} + \frac{k}{3,7D} \right]$$

where

k is the pipe equivalent uniform roughness;

D is the pipe diameter;

$\frac{k}{D}$ is the relative roughness (pure number).

Annex C shows whether a correction needs to be made, and how to calculate the correction if necessary.

If the pipe is other than unobstructed, straight, and of constant circular cross-section, the correction to be applied shall be the subject of special agreement in the contract.

8.3 Water level measurement

8.3.1 Arrangement of the measuring section

At the measuring site, the flow shall be steady and there shall be no local disturbance. If the free water surface is disturbed by small waves or swell it may be necessary, depending on the type of measuring device used, to provide a stilling well or a stilling box in communication with the basin through a perforated plate. The holes in the plate shall be small enough (about 3 mm to 5 mm in diameter) to damp the pressure fluctuations.

8.3.2 Measuring apparatus

Various types of water-level measuring apparatus may be used, according to the circumstances (free surface accessible, steady or disturbed, etc.) and to the required accuracy with regard to the pump total head. The most commonly used devices are:

- a) vertical or inclined gauges, fixed to a wall;
- b) point or hook gauges, which have an imperative need of a stilling well and a supporting frame set close above the free surface;
- c) plate gauges, consisting of a horizontal metal disk suspended from a graduated steel-ribbon tape;

- d) float gauges, only to be used in a stilling well;
- e) liquid manometers in absolute or differential form, as described in 8.4.3.1;
- f) bubbler apparatus, using a purge of compressed air;
- g) immersed pressure transducers.

The three last types are particularly suitable where the free surface is inaccessible.

Such apparatus are described in ISO 4373.

8.4 Pressure measurements

8.4.1 Pressure tapplings

For grade 1 tests, four static pressure tapplings shall be provided, symmetrically disposed around the circumference of each measuring section, as shown in Figure 8a).

For grade 2 tests it is normally sufficient to provide only one static pressure tapping at each measuring section, but when flow can be affected by a swirl or an asymmetry, two or more may be necessary [see Figure 8b)].

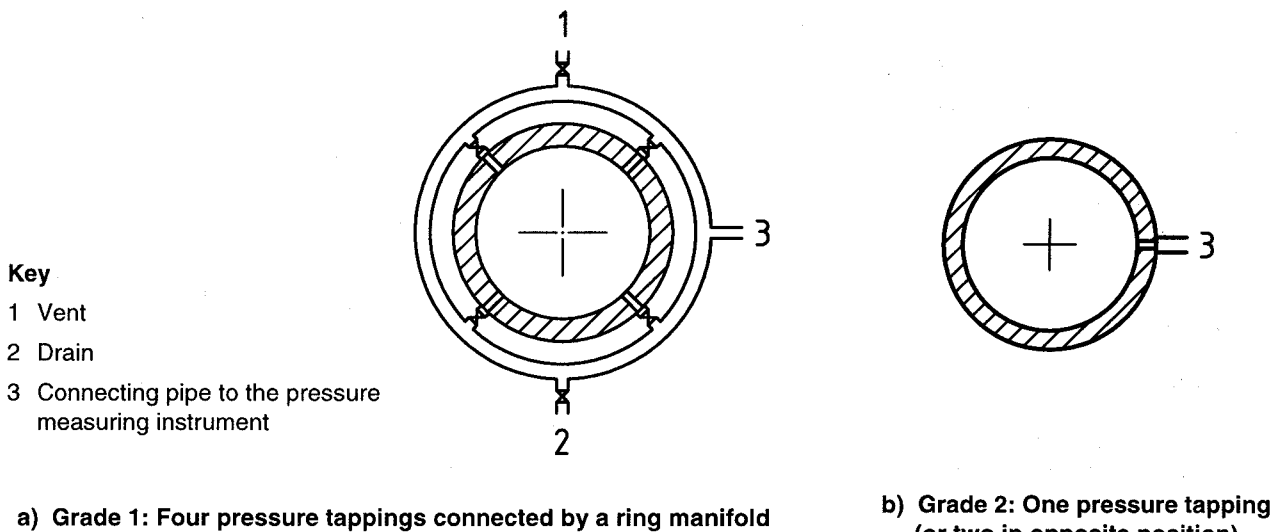

Figure 8 — Pressure tapping for grade 1 and 2 tests

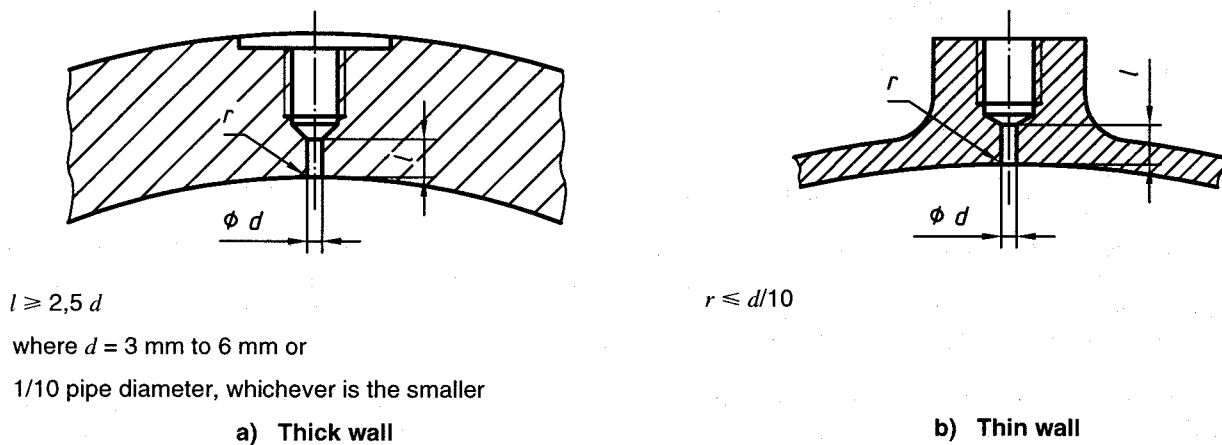

Figure 9 — Requirements for static pressure tapplings

Except in the particular case where their position is determined by the arrangement of the circuit (see 8.2.1.1 and 8.2.1.2), the pressure tapping(s) should not be located at or near the highest or the lowest point of the cross-section.

Static pressure tapings shall comply with the requirements shown in Figure 9 and shall be free from burrs and irregularities and flush with, and normal to, the inner wall of the pipe.

The diameter of the pressure tapings shall be between 3 mm and 6 mm or equal to 1/10 of the pipe diameter, whichever is the smaller. The length of a pressure tapping hole shall not be less than two and a half times its diameter.

The bore of the pipe containing the tapings shall be clean, smooth and resistant to chemical reaction with the liquid being pumped. Any coating such as paint applied to the bore shall be intact. If the pipe is welded longitudinally, the tapping hole shall be displaced as far as possible from the weld.

When several pressure tapings are used, the pressure tapings shall be connected through shut-off cocks to a ring manifold of cross-sectional area not smaller than the sum of the cross-sectional areas of the tapings, so that the pressure from any tapping may be measured if required. Before making observations, the pressure with each individual tapping successively open shall be taken at the normal test condition of the pump. If one of the readings shows a difference of more than 0,5 % of the total head with respect to the arithmetical mean of the four measurements, or if it shows a deviation of more than one times the velocity head in the measuring section, the cause of this spread shall be ascertained and the measuring conditions rectified before the actual test is started.

When the same pressure tapings are used for NPSH measurement, this deviation shall not exceed 1 % of the NPSH value or one times the inlet velocity head.

Pipes connecting pressure tapings to possible damping devices (see 5.4.2.2) and to instruments shall be at least equal in bore to the bore of the pressure tapings. The system shall be free from leaks.

Any high point in the line of the connecting pipes shall be provided with a purging valve to avoid trapping of air bubbles during measurements.

Whenever possible, it is recommended that transparent tubing be used to determine if air is present in the tubing. ISO 2186 gives indications as to the connecting pipes.

8.4.2 Correction for height difference

Correction of the pressure reading p_M for height difference ($z_M - z$) between the middle of the measuring section and the reference plane of the pressure measuring instrument shall be made by the following equation:

$$p = p_M + \rho_f \cdot g \cdot (z_M - z)$$

where ρ_f is the density of the fluid in the connecting pipe.

Care should be taken to ensure and to show that the whole length of the connecting pipe contains the same fluid. Possible errors are minimized by short horizontal connecting pipes ($z_M - z \approx 0$).

8.4.3 Pressure measuring apparatus

8.4.3.1 Liquid column manometer

Liquid column manometers which do not need to be calibrated may be used to measure low pressures.

The most commonly used manometric liquids are water and mercury, but other liquids with a density appropriate to the pressures to be measured may also be used. If possible the use of liquid columns less than 50 mm high shall be avoided. This length may be modified by providing an inclined manometer or by using an other manometric liquid. If this is impossible, attention shall be especially drawn to errors of measurement.

In order to minimize capillary effects, the bore of the manometer tubes shall be at least 6 mm for mercury gauges and 10 mm for water and other liquid gauges, and shall be the same in both branches.

The cleanness of the liquid in the manometer and of the internal surface of the tubes shall be maintained to avoid errors due to variation in surface tension.

The design of the manometer shall be such that parallax errors are minimized.

The interval between two scale graduations shall normally be 1 mm.

Liquid column manometers may be either open-ended, or closed with the air in the circuit connecting both limbs compressed to the amount required to permit the differential head to be read on the scales, or formed by a U-tube filled with the manometric liquid. In the first case, pressures are measured from a fixed reference plane and above the surrounding atmospheric pressure which is taken as constant. The two last types allow the pump total head to be obtained from a single differential measurement (see Figure 10).

When the connecting pipe is filled with air, it may happen that a residual column (height h) of pumped liquid remains at the level of the mercury, then

$$p = p_M - |\rho g h|$$

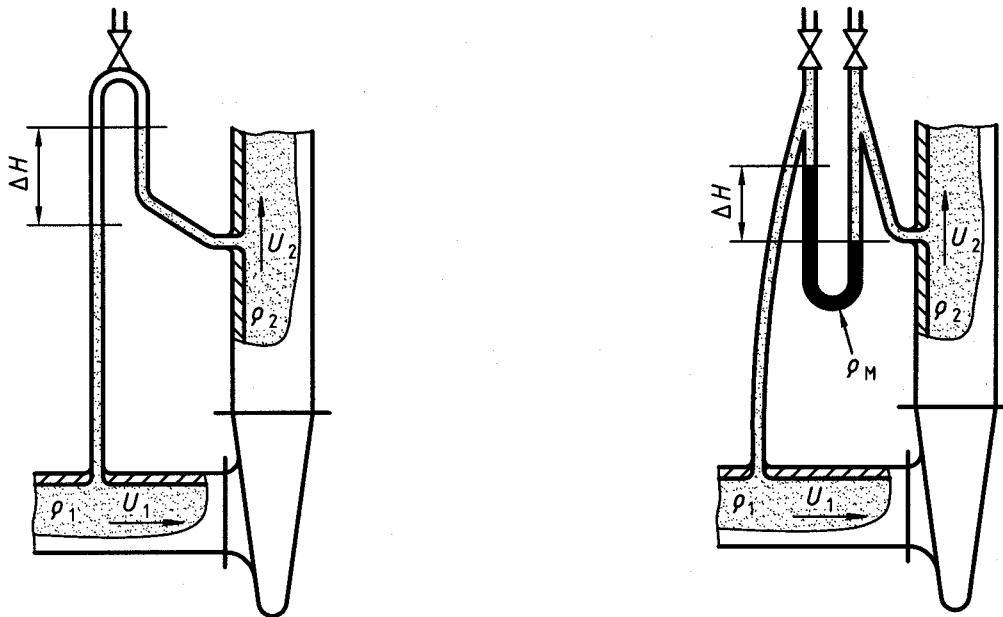

$$H = \Delta H + \frac{U_2^2 - U_1^2}{2g}$$

a) Air-water differential manometer

$$H = \frac{\rho_M - \rho_1}{\rho_1} \Delta H + \frac{U_2^2 - U_1^2}{2g}$$

b) Mercury differential manometer

NOTE The drawings show only the principle but not all technical details.

Figure 10 — Determination of pump total head by differential manometer

8.4.3.2 Dead-weight manometers

For pressures exceeding the possibility of the liquid column manometer, a dead-weight or piston manometer is of practical use whether in its simple or in its differential form. However, it can only be used beyond a minimum pressure corresponding to the weight of the rotating assembly.

The effective diameter D_e of the simple type manometer can be taken as equal to the arithmetic mean of the piston diameter D_p , measured directly, and of the cylinder diameter D_c . It can then be used for calculating pressures without further calibration if the following condition is satisfied before testing:

$$\frac{D_c - D_p}{D_c + D_p} \leq 0,1 \%$$

Friction between the piston and cylinder may be practically eliminated by rotating the piston at a speed not less than 30 min^{-1} .

It is desirable to check the weight manometer by comparison with a liquid column manometer to determine the effective piston diameter over as wide as possible a pressure range.

8.4.3.3 Spring pressure gauges

This type of gauge uses the mechanical deflection of a loop of tube, plain or spiral (Bourdon dial gauge) or a membrane to indicate pressure.

If this type of apparatus is used to measure the pressure at inlet or outlet, it is recommended that:

- each apparatus is used within its optimum measuring range (above 40 % of its full scale);
- the interval between two consecutive scale graduations is between 1,5 mm and 3 mm;
- such divisions correspond to a maximum of 5 % of the pump total head.

The calibration of this measuring apparatus shall be checked regularly.

Figure 11 shows an arrangement for determining the reference plane of spring pressure gauges.

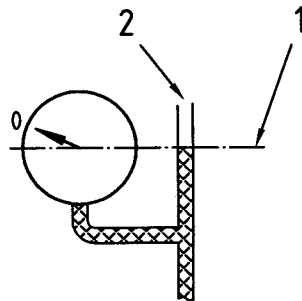

Key

- 1 Reference plane of manometer
- 2 Open to atmosphere

Figure 11 — Arrangement for determination of reference plane of spring pressure gauges

8.4.3.4 Other types of manometers

There is a large diversity of pressure transducers, absolute or differential, based on the variation of various mechanical and/or electrical properties. They may be used provided the required accuracy, repeatability and reliability are achieved, the transducer is used within its optimum measuring range, and the transducer together with its electronic equipment are calibrated regularly by comparison with a pressure device of higher accuracy and reliability.

9 Measurement of speed of rotation

The speed of rotation can be measured by counting revolutions for a measured interval of time, by a direct indicating tachometer, by a tachometric dynamo or alternator, by an optical or magnetic counter, or by a stroboscope.

In the case of a pump driven by an a.c. motor, the speed of rotation can also be deduced from observations of the grid frequency and motor slip data either supplied by the motor manufacturer or directly measured (e.g. using an induction coil). The speed of rotation is then given by the following formula:

$$n = \frac{2}{i} \left(f - \frac{j}{\Delta t} \right)$$

where

i is the number of poles of the motor;

f is the measured grid frequency, in hertz;

j is the number of images counted during the time interval Δt with a stroboscope synchronized with the grid.

Where the speed of rotation cannot be directly measured (e.g. for submersible pumps), it is usually sufficient to check the grid frequency and voltage.

10 Measurement of pump power input

10.1 General

The pump power input shall be derived from measurement of the speed of rotation and torque, or determined from measurements of the electrical power input to an electric motor of known efficiency, directly coupled to the pump.

Where the power input to an electric motor coupled to an intermediate gear, or the speed of rotation and torque measured by a torque meter between gear and motor are used as a means for determining the pump power input, the method for determining the losses due to the reduction gear shall be stated in the contract.

If necessary, see ISO 5198 for more information on the methods described in the following.

10.2 Measurement of torque

Torque shall be measured by a suitable dynamometer or a torque meter capable of complying with the requirements of Table 8.

Measurement of torque and speed of rotation shall, within practical limits, be simultaneous.

10.3 Electric power measurements

Where the electrical power input to an electric motor coupled directly to the pump is used as a means of determining the pump power input, the motor shall be operated only under conditions where the efficiency is known with sufficient accuracy. Motor efficiency shall be determined in accordance with the recommendations of IEC 60034-2 and is to be stated by the motor manufacturer.

This efficiency does not take into account motor cable losses.

The electric power input to the a.c. motor shall be measured by either the two-wattmeter or the three-wattmeter method. This allows the use of single-phase wattmeters, or a wattmeter measuring two or three phases simultaneously, or integrating watt-hour-meters.

In the case of a d.c. motor, either a wattmeter or an ammeter and a voltmeter may be used.

The type and class of accuracy of the indicating instruments for measuring electrical power shall be in accordance with IEC 60051.

10.4 Special cases

10.4.1 Pumps with inaccessible ends

In the case of combined motor-pump units (e.g. submersible pump or monobloc pump; or separate pump and motor with overall efficiency guarantee), the power of the unit shall be measured at the motor terminals if accessible. When a submersible pump is involved, the measurement shall be effected at the incoming end of the cables; cable losses shall be taken into account and specified in the contract. The efficiency given shall be that of the combined unit proper, excluding the cable and the starter losses.

10.4.2 Deep-well pumps

In this case, the power absorbed by the thrust bearing and the vertical shafting and bearings shall be taken into account.

Since deep-well pumps in general are not tested with the entire stand pipe attached, unless the acceptance test is performed at site, the thrust and vertical shaft bearing losses shall be estimated and stated by the manufacturer/supplier.

10.4.3 Motor pump units with common axial bearing (other than close-coupled pumps)

In this case, if the power and the efficiency of the motor and those of the pump shall be determined separately, the influence of the axial thrust and possibly of the weight of the pump rotor on the losses in the thrust bearing shall be taken into account.

10.4.4 Measurement of pumping unit overall efficiency

To determine the efficiency of a pumping unit, only the power input and output are measured, with the driver working under conditions specified in the contract. In this test, the proportion of losses between driving agent and pump is not established, nor any losses associated with intermediate machinery such as gear box or variable speed devices.

11 Cavitation tests

11.1 General

11.1.1 Object of cavitation tests

This International Standard deals only with measurements relating to the hydraulic performance of the pump (variations of head, flow, efficiency) and not with other effects which can be caused by cavitation (noise, vibrations, material damage, etc.).

In no case shall the cavitation tests be used to check that the pump will be free from cavitation erosion during its service life.

Cavitation can be detected as a decrease in head or efficiency at a given flow rate or as a decrease in flow rate or efficiency at a given head. Mostly the criterion of head drop at a given flow rate is used. In the case of multistage pumps, the head drop shall be relative to the head of the first stage, which should be measured if accessible.

In most cases cavitation tests will be conducted with clean cold water. Cavitation tests in water cannot accurately predict the behaviour of the pump with liquids other than clean cold water (see 5.4.5).

In the case of tests with liquids at high temperature or near their critical points, it may be difficult or even impossible to measure the NPSH with the required accuracy (see 11.3.3).

11.1.2 Test types

11.1.2.1 Verification of guaranteed characteristics at a specified NPSHA

A check may be made simply to determine the hydraulic performance of the pump at the specified NPSHA without exploring what the cavitation effects are.

The pump meets the requirements if the guaranteed pump total head and efficiency are obtained according to 6.4.1 under the specified flow rate and under the specified NPSHA.

11.1.2.2 Verification of the absence of influence of cavitation on the performance at a specified NPSHA

A check may be made to show that the hydraulic performance of the pump is not affected by cavitation at the specified operating conditions.

The pump meets the requirement if a test at a higher NPSH value than the specified NPSHA gives the same total head and efficiency at the same flow rate.

11.1.2.3 Determination of NPSH3

In this test NPSH is reduced progressively until the drop of the total head (of the first stage) at constant flow rate reaches 3 %. This value of NPSH is NPSH3 (see Table 11 and Figures 12 to 14.).

For very low head pumps, a larger head drop may be agreed upon.

Table 11 — Methods of determining NPSH3

Type of installation	Open sump	Open sump	Open sump	Open sump	Open sump	Closed loop	Closed loop	Closed loop	Closed sump or loop
Independent variable	Inlet throttle valve	Outlet throttle valve	Water level	Inlet throttle valve	Water level	Pressure in the tank	Temperature (vapour pressure)	Pressure in the tank	Temperature (vapour pressure)
Constant	Outlet throttle valve	Inlet throttle valve	Inlet and outlet throttle valves	Flow rate	Flow rate	Flow rate	Flow rate	Inlet and outlet throttle valves	
Quantities the variation of which is dependent on control	Total head, flow rate, NPSHA, water level	Total head, flow rate, NPSHA, water level	Total head, flow rate, NPSHA	NPSHA, total head, outlet throttle valve, (for constant flow rate)	NPSHA, total head; outlet throttle valve	Total head, NPSHA, outlet throttle valve (for constant flow rate; when total head begins to drop)	NPSHA, head, outlet throttle valve (for constant flow rate, when head begins to drop)	NPSHA; total head and flow rate, when a certain level of cavitation is reached	
Head characteristic curve versus flowrate and NPSH	See Figure 12a)			See Figure 13a)				See Figure 14a)	
NPSH characteristic curve versus flowrate	See Figure 12b)			See Figure 13b)				See Figure 14b)	

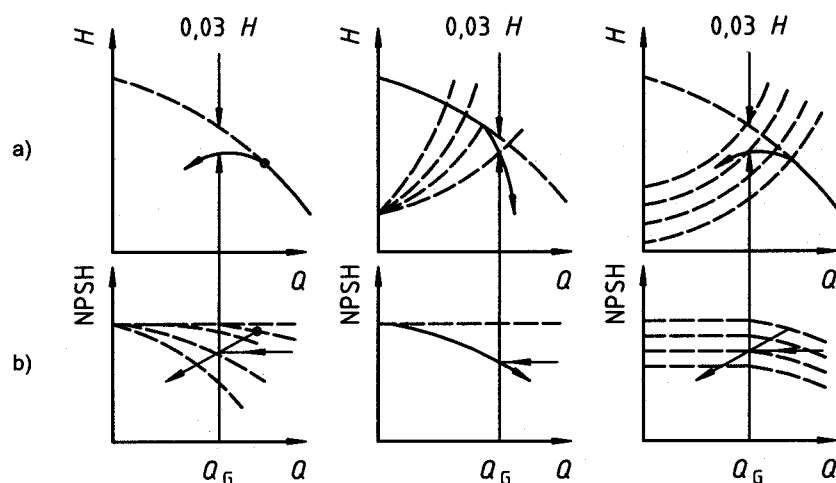

Figure 12

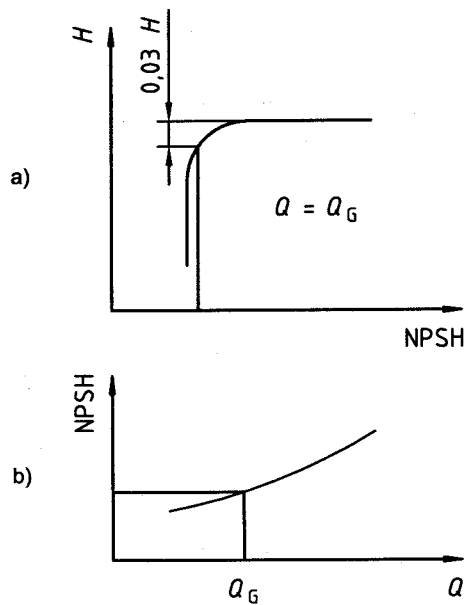

Figure 13

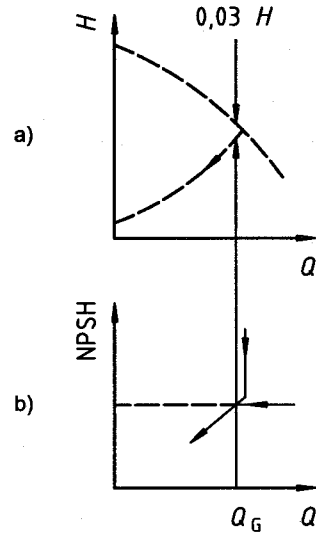

Figure 14

11.1.2.4 Other cavitation tests

Other cavitation criteria (e.g. increase of noise) and corresponding types of cavitation tests may be used. In this case special agreement in the contract is necessary.

11.2 Test installations

11.2.1 General

The test described in 11.1.2 can be conducted by any of the methods indicated in Table 11 and in any of the installations described in the following clauses.

It is possible to vary two control parameters and thus keep the flow rate constant during a test, but this is usually more difficult.

11.2.2 General characteristics of the circuit

The circuit shall be such that when cavitation appears in the pump, it shall not occur elsewhere to an extent where it affects the stability or the satisfactory operation of the installation or the measurement of the pump performance.

It shall be ensured that cavitation and the bubbles and degassing produced by cavitation in the pump do not affect the functioning of the instrumentation, particularly the flow measuring device.

The measuring conditions on the cavitation test rig, whether this be the same as that used for the determination of the efficiency curves or not, shall conform to the conditions specified in 5.3 and 5.4.

The types of installations described in 11.2.4 may necessitate special regulating valves at the inlet and outlet to avoid cavitation in these items which could influence results.

Cavitation in the flow through a throttle valve can sometimes be prevented by using two or more throttle devices connected in series, or by arranging for the throttle valve to discharge directly into a closed vessel or a large diameter tank interposed between the throttle and the pump inlet. Baffles and means of extracting air from such a vessel may be needed, especially when the NPSH is low.

When a throttle valve is partially closed, it is necessary to make sure that the pipe is full of liquid and that pressure and velocity distributions at the inlet measuring section are uniform. This may be achieved by use of a suitable flow straightening device and/or a long straight pipe of at least $12 D$ length at the pump inlet.

11.2.3 Characteristics of the test liquid

The liquid shall be clean and clear and should not contain solid matter. As far as possible free gas should be removed before the test.

De-aeration of water used for a cavitation test is necessary only if the pump is to be used in practice with de-aerated water.

Conversely, to avoid de-gassing in any part of the pump, the water of the circuit should not be supersaturated.

The general flow conditions stipulated in 5.3 and 5.4, especially at the inlet of the pump, shall be fulfilled.

11.2.4 Types of installation

NOTE 1 In 11.2.4.1 to 11.2.4.3, various types of installations which may be used are described. Such installations may not be suitable for liquids other than cold water as the uncertainty in temperature measurement may produce an excessive error in the determination of vapour pressure.

NOTE 2 Tests using the installations described in 11.2.4.1 and 11.2.4.2 will give the more precise and reliable results compared to tests using the installation described in 11.2.4.3.

11.2.4.1 Closed-loop arrangement

The pump is installed in a closed pipe loop as shown in Figure 15 in which by altering the pressure, level or temperature, the NPSH is varied without influencing the pump head or flow rate until cavitation occurs in the pump.

Arrangements for cooling or heating the liquid in the loop may be needed in order to maintain the required temperature, and a gas separation tank may also be required,

A liquid recirculation loop may be necessary to avoid unacceptable temperature difference in the test tank.

The tank shall be of sufficient size and so designed as to prevent the entrainment of gas in the pump inlet flow. Additionally, stilling screens may be needed in the tank if the average velocity exceeds 0,25 m/s.

11.2.4.2 Open sump with level control

The pump draws liquid through an unobstructed suction pipe from a sump in which the level of the free liquid surface may be adjusted (Figure 16).

11.2.4.3 Open sump with throttle valve

The pressure of the liquid entering the pump is adjusted by means of a throttle valve installed in the inlet pipe at the lowest practicable level (Figure 17).

11.3 Determination of the NPSH required by the pump

11.3.1 Methods of measuring various quantities

If not otherwise agreed the methods for the measurement of head, flow rate, speed of rotation and (if necessary) power input during cavitation tests are those given in clauses 7 to 10.

Particular care is needed to ensure that in the measurement of flow cavitation does not affect the accuracy of the flowmeter. It is also necessary to take care to avoid the ingress of air through joints and glands (e.g. by using a water seal/barrier liquid).

If the test conditions are so unsteady as to require repeated readings, variations in NPSH are permitted up to a maximum of

- 1,5 times the values given for head in Table 7, or
- 0,2 m,

whichever is the greater.

11.3.2 Determination of pressure

The vapour pressure of the test liquid entering the pump shall be determined with sufficient accuracy to comply with 11.3.3. When the vapour pressure is derived from standard data and the measurement of the temperature of the liquid entering the pump, the necessary accuracy of temperature measurement shall be demonstrated.

The source of standard data to be used shall be agreed between manufacturer/supplier and purchaser.

The active element of a temperature measuring probe shall be not less than 1/8 of the inlet pipe diameter from the wall of the inlet pipe. If the immersion of the temperature measuring element in the inlet flow is less than that required by the instrument manufacturer, then a calibration at that immersion depth will be required.

Care shall be taken to ensure that temperature measuring probes inserted into the pump inlet pipe do not influence the measurements of inlet pressure.

11.3.3 Tolerance factor for NPSHR

The maximum permissible value of the difference between measured and guaranteed NPSHR is

- for grade 1: $t_{\text{NPSHR}} = +3\%$ or $t_{\text{NPSHR}} = +0,15\text{ m}$,
- for grade 2: $t_{\text{NPSHR}} = +6\%$ or $t_{\text{NPSHR}} = +0,30\text{ m}$,

whichever is the greater.

Using the following formula, the guarantee is met if:

$$(\text{NPSHR})_{\text{G}} + t_{\text{NPSHR}} \cdot (\text{NPSHR})_{\text{G}} \geq (\text{NPSHR})_{\text{measured}}, \text{ or}$$

$$(\text{NPSHR})_{\text{G}} + (0,15\text{ m, respectively } 0,3\text{ m}) \geq (\text{NPSHR})_{\text{measured}}.$$

Figures 15 to 17 show the principle but no technical details and can be taken as examples.

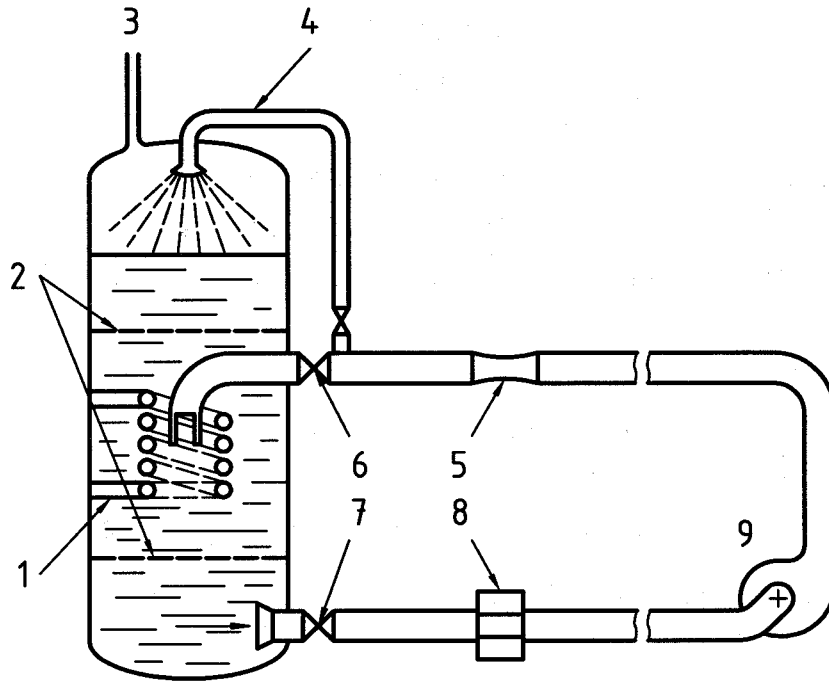

NOTE Cooling by means of a coil may be replaced by an injection of cool water above the liquid free surface and extraction of heated water.

Key

- | | | |
|---------------------------------|---------------------------------------|-----------------------------------|
| 1 Cooling or heating coils | 4 Spray nozzle for liquid de-aeration | 7 Isolating valve |
| 2 Stilling screens | 5 Flowmeter | 8 Measuring point for gas content |
| 3 To vacuum or pressure control | 6 Flow control valve | 9 Test pump |

Figure 15 — Cavitation tests: Variation of NPSH by means of a closed loop controlling pressure and/or temperature

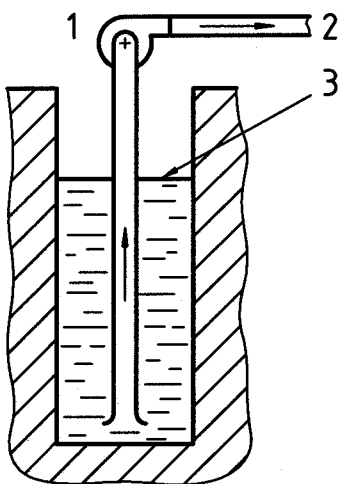

Key

- 1 Test pump
- 2 To flow control valve and flowmeter
- 3 Adjustable water level

Figure 16 — Cavitation tests: Variation of NPSH by control of liquid level at pump inlet sump

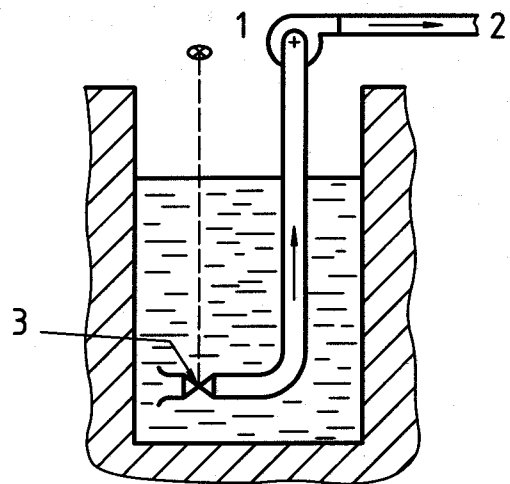

Key

- 1 Test pump
- 2 To flow control valve and flowmeter
- 3 Inlet pressure control valve

Figure 17 — Cavitation tests: Variation of NPSH by means of an inlet pressure control valve

Annex A (normative)

Tolerance factors for pumps produced in series with selection made from typical performance curves and for pumps with a driver power input less than 10 kW (relevant to series pumps grade 2)

NOTE This annex applies only to the allowable working range of the pump.

A.1 Pumps produced in series with selection made from typical performance curves

The performance curves in catalogues represent the mean (not the minimal) performances of a series of pumps of the same type. This applies also to efficiency and power input. Therefore increased tolerances and even tolerances on power are necessary.

When the manufacturer/supplier makes reference in his catalogue to this annex, the following maximum factors shall be used:

- for flow rate $t_Q = \pm 9 \%$
- for pump total head $t_H = \pm 7 \%$
- for pump power input $t_P = + 9 \%$
- for driver power input $t_{P_{gr}} = + 9 \%$
- for efficiency $t_\eta = - 7 \%$

A.2 Pumps with a driver power input less than 10 kW

For pumps with driver power input less than 10 kW but greater than 1 kW, where friction losses in various mechanical components become relatively important and not easily predictable, the tolerance factors given in Table 10 may not be applicable. In this case the tolerance factors shall be follows:

- flow rate $t_Q = \pm 10 \%$
- pump total head $t_H = \pm 8 \%$

The tolerance factor on efficiency, t_η , if not otherwise agreed, may be calculated as follows:

$$t_\eta = - \left[10 \left(1 - \frac{P_{gr}}{10} \right) + 7 \right] \%$$

where P_{gr} is the maximum driver power input in kilowatts over the range of operation. A tolerance factor $t_{P_{gr}}$ is allowed using the following formula:

$$t_{P_{gr}} = \sqrt{(7 \%)^2 + t_\eta^2} \%$$

NOTE For pumps with very small power input (less than 1 kW), another special agreement may be decided between the parties.

Annex B (normative)

Determination of reduced impeller diameters

If the characteristics of the pump are higher than the specified characteristics, a reduction of the impeller diameter is generally carried out.

Subject to the agreement mentioned in 6.5.1, the following rule may be applied where the ratio of reduction of the mean outlet diameter of the impeller does not exceed 5 % for pumps of type number $K \leq 1,5$ if the shape of the blades remains unaltered after cutting (outlet angle, tapering, etc.).

The law allowing the evaluation of the new characteristics is:

$$R = \left(\frac{D_r^2 - D_t^2}{D_t^2 - D_1^2} \right)^{\frac{1}{2}}$$

where

D is the diameter as given in Figure B.1

subscript t = test

r = reduced

$$Q_r = R \cdot Q_t$$

$$H_r = R^2 \cdot H_t$$

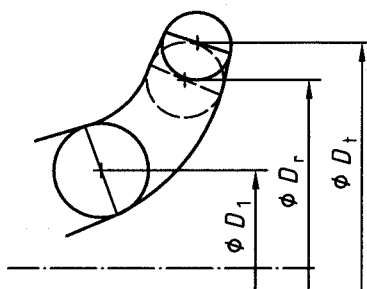

Figure B.1 — Reduced impeller diameters

The efficiency may be assumed to be practically unaltered between the operating points for pumps of type number $K \leq 1,0$ and for a reduction of the impeller diameter of not more than 3 %.

Annex C (normative)

Friction losses

The formula given in 8.2.4 for calculating head losses due to friction involves a lengthy calculation, which in many cases would lead to the conclusion that a correction need not be applied.

A preliminary check as to whether a calculation needs to be made is given in Figure C.1 for grade 1 tests and Figure C.2 for grade 2 tests. They apply to straight steel pipes of constant circular cross-section, handling cold water. Inlet and outlet pipes are assumed to be of equal diameter, and measuring points are two diameters upstream and downstream of the inlet and outlet flanges respectively (see 8.2.1).

If the pipes are of different diameters, the diameter of the smaller pipe should be used. Then if "no correction" is indicated, the calculation need not be made.

If "correction" is indicated, Figure C.3 (which applies only to steel pipes handling cold water) may be used to determine the value of λ . In cases where pipes are of other material or the liquid is not cold water, the graph by Moody given in Figure C.4 may be used, or the formula for λ given in 8.2.4 may, if preferred, be solved. For the pipe roughness k the values given in Table C.1 may be taken.

Table C.1 — Equivalent uniform roughness k for pipes

Commercial pipe (new) material	Equivalent uniform roughness k of the surface mm
Glass, drawn brass, copper or lead	smooth
Steel	0,05
Asphalted cast iron	0,12
Galvanized iron	0,15
Cast iron	0,25
Concrete	0,30 to 3,0
Riveted steel	1,0 to 10,0

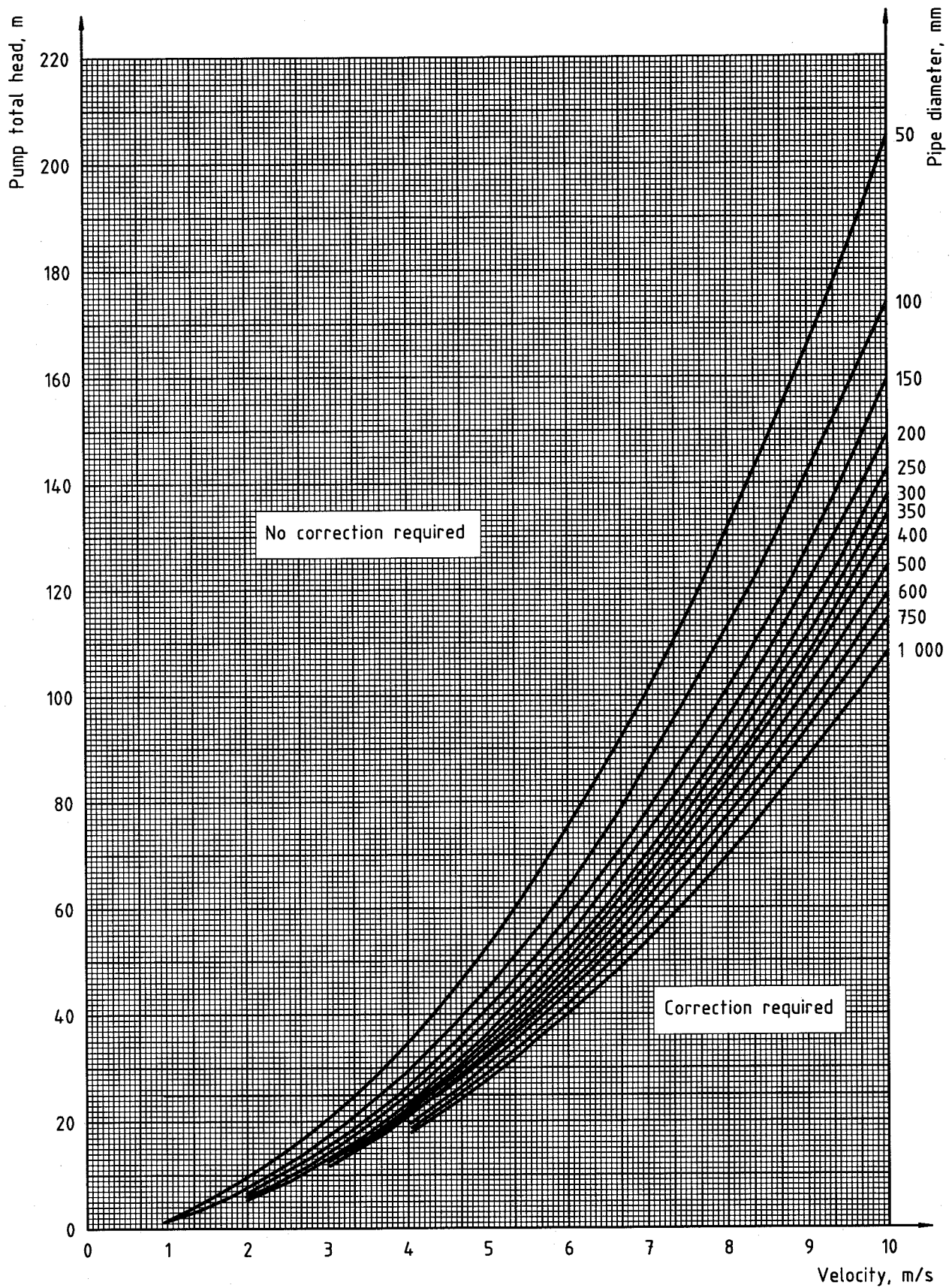

Figure C.1 — Chart for grade 1 tests showing velocities above which loss corrections are required (for measuring sections placed $2D$ upstream and downstream of the pump flanges)

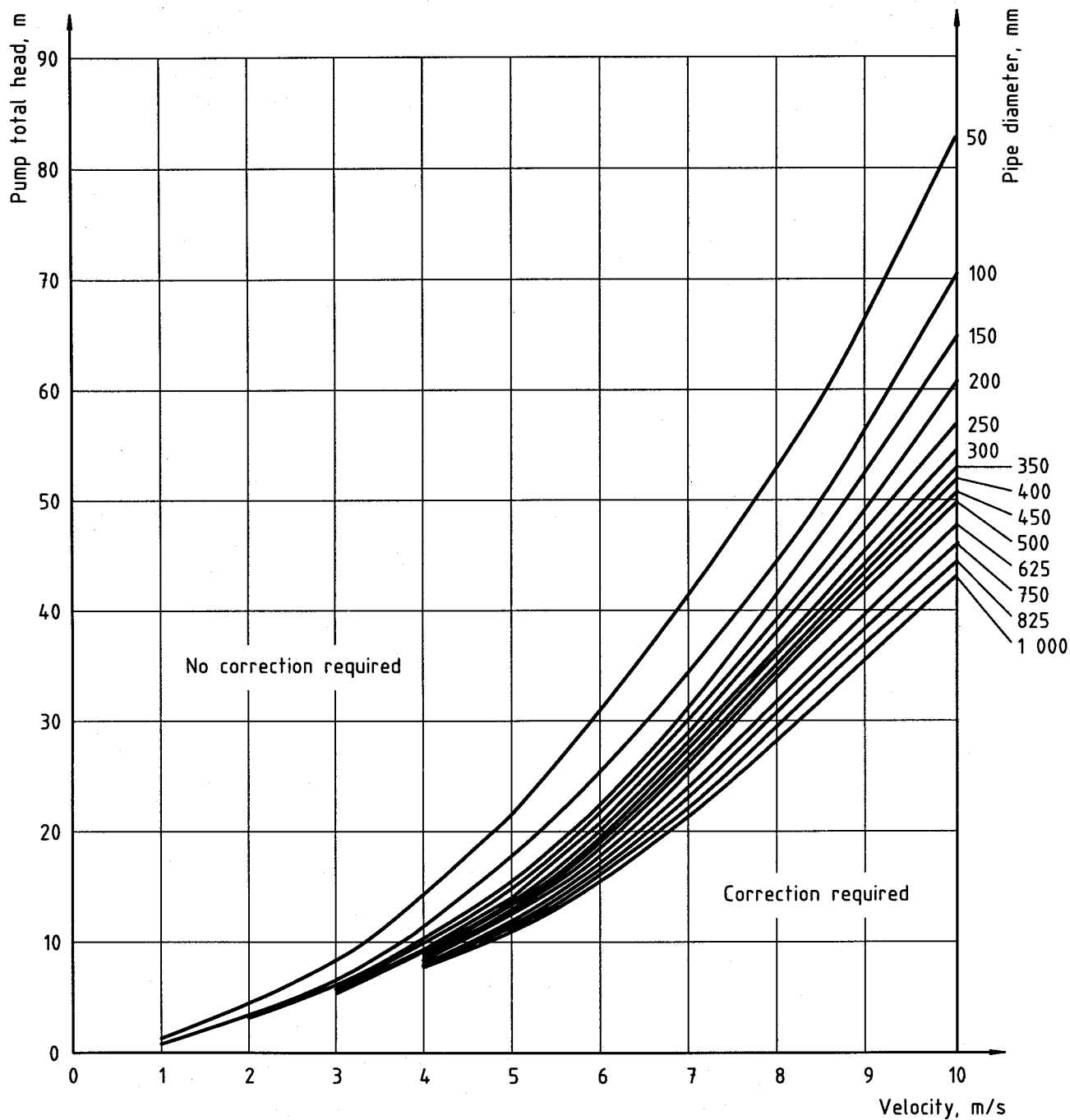
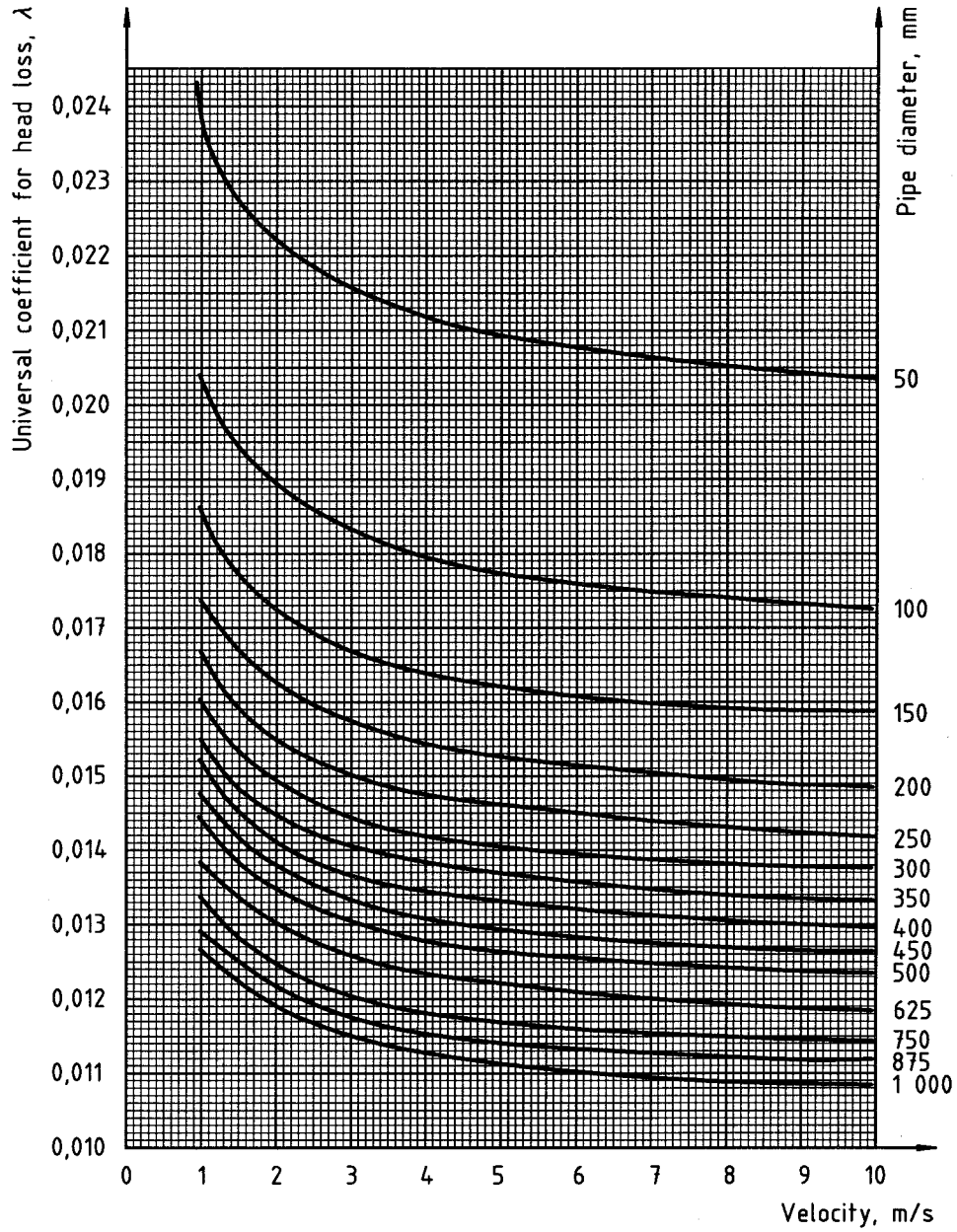

Figure C.2 — Chart for grade 2 tests showing velocities above which loss corrections are required (for measuring sections placed 2D upstream and downstream of the pump flanges)



Surface roughness $k = 5 \times 10^{-5} \text{ m}$
 Kinematic viscosity $\nu = 1 \times 10^{-6} \text{ m}^2/\text{s}$

Figure C.3 — Universal coefficient for head loss

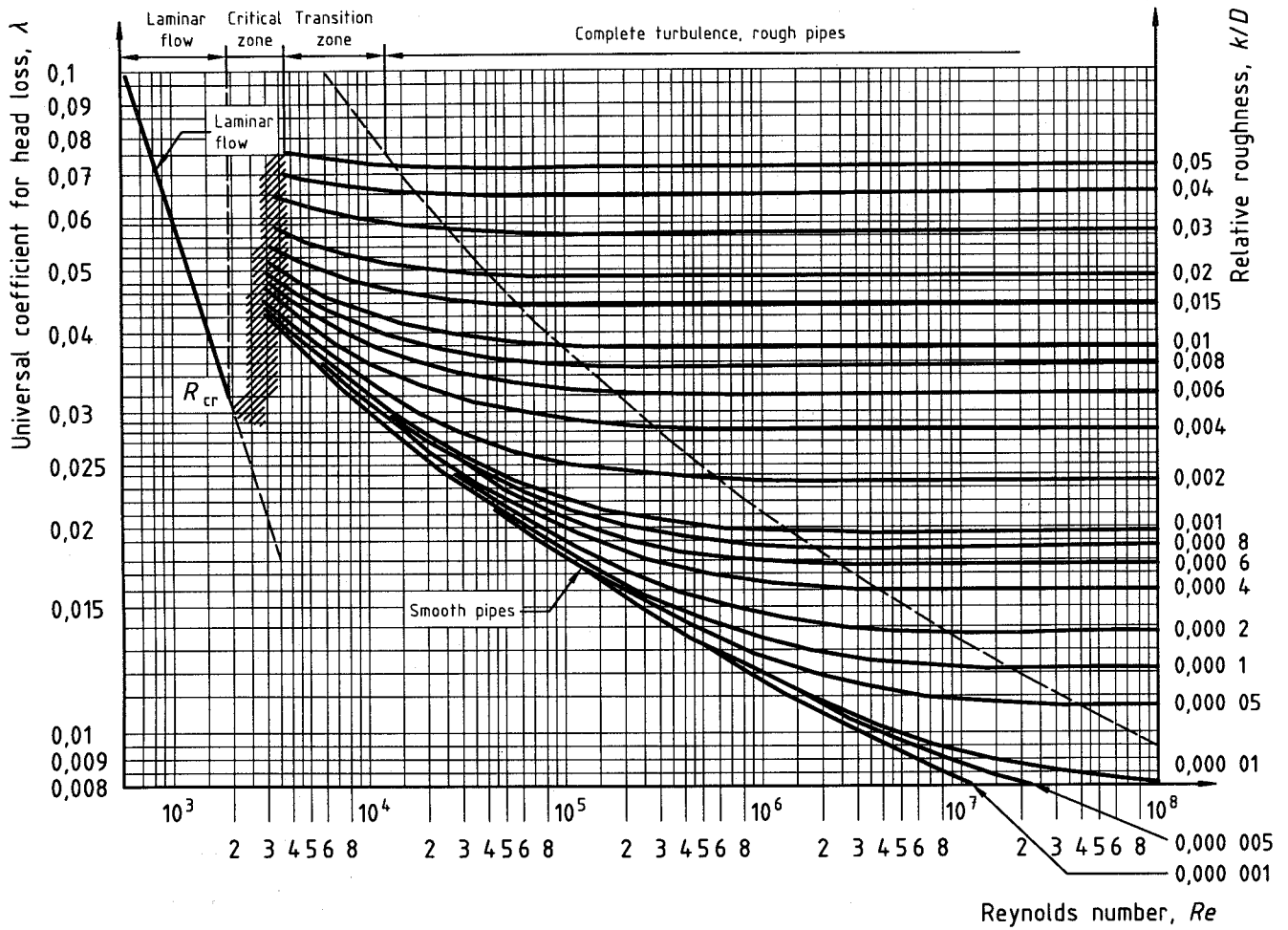

Figure C.4 — Values of universal coefficient for head loss (Moody chart)

Annex D (informative)

Conversion to SI Units

Table D.1 gives factors for the conversion to SI units of some of the quantities expressed in multiples or sub-multiples of SI units and in units other than SI units. The conversion factor is the number by which the value expressed in various units should be multiplied to find the corresponding value in SI units.

Table D.1 — Conversion factors

Quantity	Symbol of SI unit	Various units		Conversion factors
		Name	Symbol	
(Volume) rate of flow	m ³ /s	litre per second	l/s	10 ⁻³
		cubic metre per hour	m ³ /h	1/3600
		litre per hour	l/h	1/3600000
		litre per minute	l/min	1/60000
		imperial gallon per minute	gal (UK)/min	75,77 × 10 ⁻⁶
		cubic foot per second	ft ³ /s	28,3168 × 10 ⁻³
		gallon (US) per minute	gal (US)/min	63,09 × 10 ⁻⁶
		barrel (US) per hour (petroleum)	barrel (US)/h	44,16 × 10 ⁻⁶
Mass rate of flow	kg/s	tonne per second	t/s	10 ³
		tonne per hour	t/h	1/3,6
		kilogram per hour	kg/h	1/3600
		pound per second	lb/s	0,45359237
Pressure	Pa	kilopond per square centimetre	kp/cm ²	98066,5
		kilogram-force per square centimetre	kgf/cm ²	98066,5
		bar	bar	10 ⁵
		hectopieze	hpz	10 ⁵
		torr	torr	133,322
		conventional millimetre of mercury	mmHg	133,322
		conventional millimetre of water	mmH ₂ O	9,80665
		poundal per square foot	pdl/ft ²	1,48816
		standard atmosphere	atm	101325
		pound-force per square inch	lbf/in ² (psi)	6894,76
Density	kg/m ³	kilogram per cubic decimetre	kg/dm ³	10 ³
		gram per cubic centimetre	g/cm ³	10 ³
		pound per cubic foot	lb/ft ³	16,0185
Power	W	kilowatt	kW	10 ³
		kilopond metre per second	kp · m/s	9,80665
		I.T. kilocalorie per hour	kcal _{I.T.} /h	1,163
		cheval vapeur	ch	735,5
		horsepower	hp	745,7
		British thermal unit per hour	Btu/h	0,293071
		kilogram-force metre per second	kgf · m/s	9,80665
Viscosity (dynamic viscosity)	Pa s	poise	P	10 ⁻¹
		dyne second per square centimetre	dyn · s/cm ²	10 ⁻¹
		gram per second centimetre	g/s · cm	10 ⁻¹
		kilopond second per square metre	kp · s/m ²	9,80665
		poundal second per square foot	pdl · s/ft ²	1,48816
Kinematic viscosity	m ² /s	stokes	St = cm ² /s	10 ⁻⁴
		square foot per second	ft ² /s	92,903 × 10 ⁻³

Annex E (informative)

Guide for suitable time periods between calibrations of test instruments

The information given in Table E.1, partly based on "Hydraulic Institute Test Standards, 1988, Centrifugal Pumps 1-6", are given for guidance only. The actual time interval between calibrations depends upon the experience available for any test facility and associated equipment and should be specified in the quality assurance procedure for the test rig.

Table E.1 — Suitable time periods between calibration of test instruments

Values in years unless indicated by "mo" for months

Equipment	Period	Equipment	Period
Flow rate		Power	
Weighing tank	1	Dynamometer	6 mo
Volumetric tank	10	Torque bar	1
Venturi	a	Calibrated motor	Not required
Nozzle	a	Watt-amp-volt-meter, portable	1
Orific plate	a	Watt-amp-volt-meter, permanent	3
Turbine	1	Torque meter with strain gauge	6 mo
Electromagnetic	1	Intermediate gears to 375 kW	10 mo
Weir	a	Intermediate gears above 375 kW	20 mo
Current meter	2	Speed	
Ultrasonic	6 mo	Tachometer (general)	3
Pressure		Electronic	1
Spring pressure gauge	4 mo	Frequency responsive devices	
Dead weight	Not required	magnetic	10
Liquid column manometers	Not required	optical	10
Transducers	4 mo	Stroboscopes	5
		Torquemeter (speed)	1
^a Not required unless suspected critical dimensional change.			

Annex F

(informative)

Costs and repetition of tests

NOTE Matters of purely commercial nature such as the cost of the test are not included in the scope of this International Standard and should be the subject of special agreements between the parties concerned.

F.1 Costs of acceptance test and special tests

It is recommended that the costs of acceptance tests and special tests be clearly stated in the contract.

Attention is to be drawn to the fact that test costs increase if NPSH tests are to be made.

F.2 Repetition of tests

In case of doubt as to the correctness or adequate accuracy of the measurement data obtained, both the manufacturer/supplier and purchaser are entitled to demand that the test be repeated. Should the new measurement fail to justify the doubts expressed, the party demanding the renewed test shall carry the cost of repetition.

Annex G (informative)

Performance correction chart for viscous liquids

Figure G.1 is a performance correction chart for determining the performance of a conventional centrifugal pump handling a viscous liquid when its performance on water is known. The correction curves are not exact for any particular pump.

When accurate information is essential, performance tests should be conducted with the particular viscous liquid to be handled.

Since Figure G.1 is based on empirical rather than theoretical considerations, extrapolation beyond the limits shown would go outside the experience range which these charts cover and is not recommended.

It is applicable only to pumps of conventional hydraulic design, in the normal operating range, with open or closed impellers. It is not to be used for mixed flow or axial flow pumps, or for pumps of special hydraulic design for either viscous or non-uniform liquids.

Figure G.1 applies only where adequate NPSH is available in order to avoid cavitation.

It should be used only for Newtonian (uniform) liquids. Gels, slurries, paper stock and other non-uniform liquids may produce widely varying results, depending on the particular characteristics of the liquids.

The symbols and definitions given in Table G.1 are used in this annex.

Table G.1 — Additional symbols and definitions used in Annex G

Symbol	Quantity	Definition
Q_{vis}	Viscous flow rate	flow rate when pumping a viscous liquid
H_{vis}	Viscous head	head when pumping a viscous liquid
η_{vis}	Viscous efficiency	efficiency when pumping a viscous liquid
P_{vis}	Viscous power input	power input required by the pump for the viscous conditions
Q_W	Water flow rate	flow rate when pumping water
H_W	Water head	head when pumping water
η_W	Water efficiency	efficiency when pumping water
ρ	Density	
C_Q	Flow rate correction factor	
C_H	Head correction factor	
C_η	Efficiency correction factor	
Q_{NW}	Water flow rate at which maximum efficiency is obtained	

The following equations are used for determining the viscous performance when the water performance of the pump is known:

$$Q_{\text{vis}} = C_Q \times Q_W$$

$$H_{\text{vis}} = C_H \times H_W$$

$$\eta_{\text{vis}} = C_\eta \times \eta_W$$

$$P_{\text{vis}} = \frac{Q_{\text{vis}} \times H_{\text{vis}} \times \rho \times g}{\eta_{\text{vis}}}$$

C_Q , C_H and C_η are determined from Figure G.1, which is based on water performance.

From the efficiency curve, locate the water flow rate ($1,0 \times Q_{\text{NW}}$) at which maximum efficiency is obtained.

From this flow rate, determine the flow rate: ($0,6 \times Q_{\text{NW}}$), ($0,8 \times Q_{\text{NW}}$) and ($1,2 \times Q_{\text{NW}}$).

Enter the chart at the bottom with the flow rate at best efficiency ($1,0 \times Q_{\text{NW}}$), go upward to the head developed (in one stage) (H_W) at this flow rate, then horizontally (either left or right) to the desired viscosity, and then proceed upward to the various correction curves.

Read the values of C_η and C_Q , and of C_H for all four flow rates.

Multiply each head by its corresponding head correction factor to obtain the corrected heads. Multiply each efficiency value by C_η to obtain the corrected efficiency values which apply at the corresponding corrected flow rate.

Plot corrected head and corrected efficiency against corrected flow rate. Draw smooth curves through these points. The head at shut-off can be taken as approximately the same as that for water.

Calculate the viscous power input (P_{vis}) from the formula given above.

Plot these points and draw a smooth curve through them which should be similar to and approximately parallel to the power input curve for water.

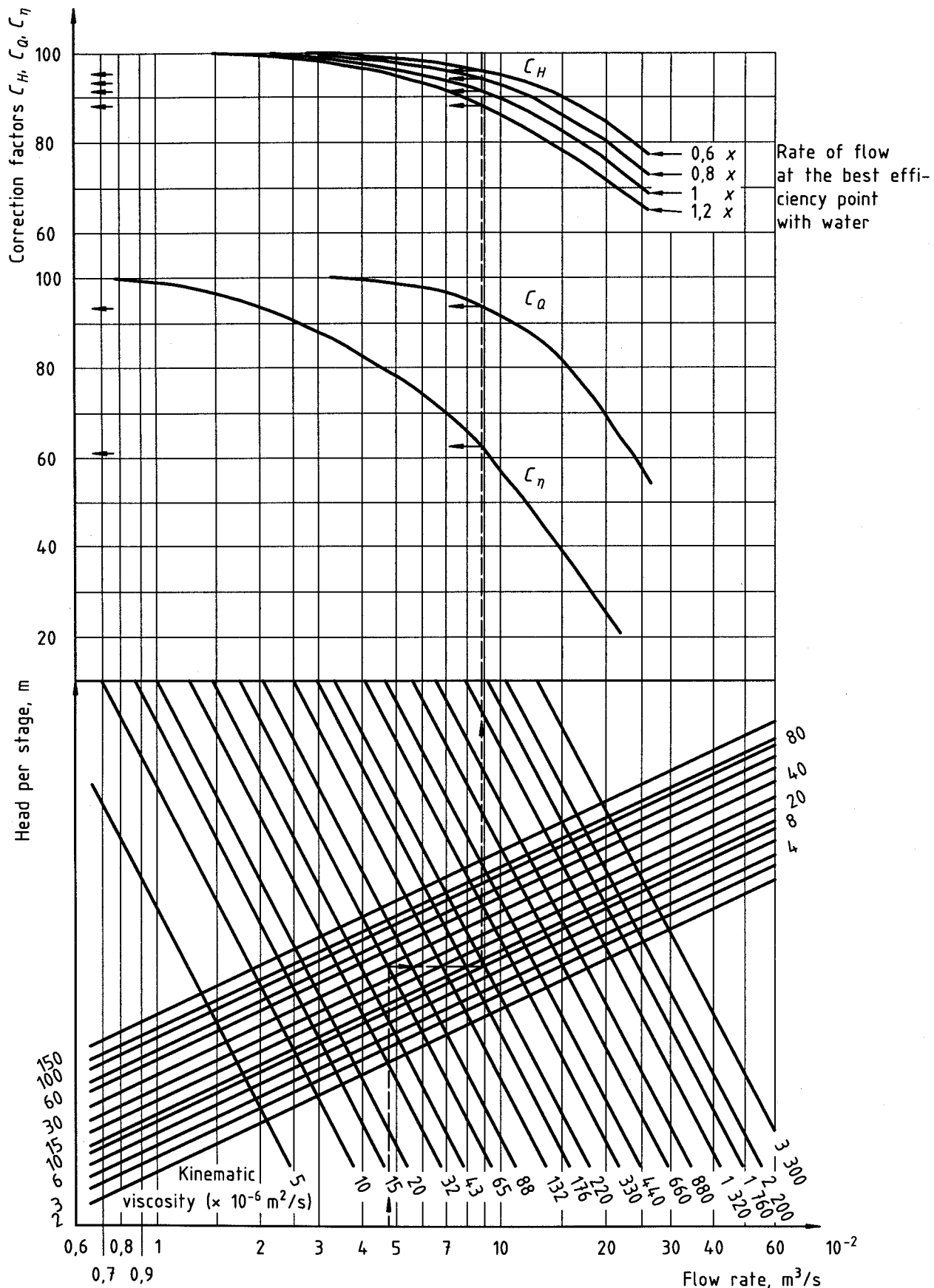

NOTE The values shown in this figure are averages from tests of conventional single-stage centrifugal pumps of DN 50 to DN 200 handling petroleum oils. These data are based on Hydraulic Institute Standards (HIS), 1985.

Figure G.1 — Performance correction chart for viscous liquids

Annex H (informative)

NPSHR reduction for pumps handling hydrocarbon liquids and high temperature water

Figure H.1 is a composite chart of NPSHR reductions which may be expected for hydrocarbon liquids and high temperature water, based on available laboratory data from tests conducted on the fluids shown, plotted as a function of fluid temperature and vapour pressure at that temperature.

The following limitations and precautions should be observed in the use of Figure H.1.

Until specific experience has been gained with operation of pumps under conditions where this chart applies, NPSHR reduction should be limited to 50 % of the NPSHR required by the pump for cold water.

This chart is based on pumps handling pure liquids. Where entrained air or other non-condensable gases are present in a liquid, pump performance may be adversely affected even with normal NPSHA values and would suffer further with reduction in NPSHA. Where dissolved air or other non-condensables are present, and where the absolute pressure at the pump inlet would be low enough to release such non-condensables from solution, the NPSHA value may have to be increased above that required for cold water to avoid deterioration of pump performance due to such release.

For hydrocarbon mixtures, vapour pressure may vary significantly with temperature, and specific vapour pressure determinations should be made for actual pumping temperatures.

In the use of the chart for high temperature liquids, and particularly with water, due consideration should be given to the susceptibility of the suction system to transient changes in temperature and absolute pressure, which might necessitate provision of a margin of safety of NPSHR far exceeding the reduction otherwise available for steady-state operation.

Because of the absence of available data demonstrating NPSHR reduction greater than 3 m, the chart has been limited and extrapolation beyond that limit is not recommended.

Enter Figure H.1 at the bottom of the chart with pumping temperature, in degrees Celsius, and proceed vertically upward to the vapour pressure. From this point, follow along or parallel to the sloping lines to the right side of the chart, where the NPSHR reduction may be read on the scale provided. If this value is greater than one half of the NPSHR value for cold water, deduct one-half of the cold water NPSHR value to obtain corrected NPSHR. If the value on the chart is less than one-half of the cold water NPSHR value, deduct this chart value from the cold water NPSHR value to obtain the corrected NPSHR.

NOTE 1 Available data are limited to the liquids for which the temperature-vapour pressure relationship is shown on the figure. Application of this chart to liquids other than hydrocarbons and water is not recommended without experimental basis.

NOTE 2 The NPSHR reduction actually applied to the NPSHR value for cold water is:

- either the value read on the right-hand scale of the chart,
- or one-half the NPSHR for cold water,

whichever is the smaller.

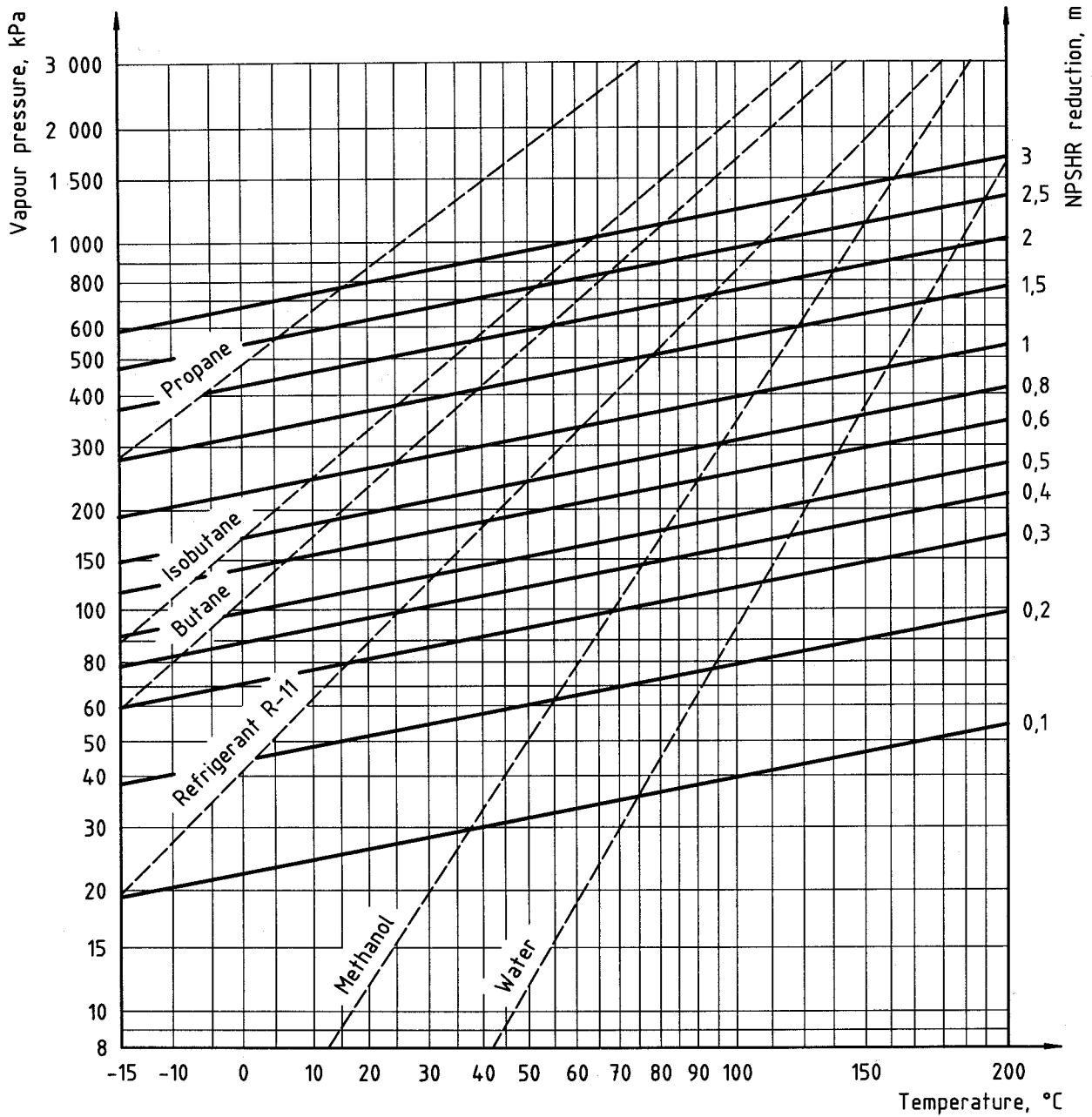

NOTE These data are based on Hydraulic Institute Standards (HIS), 1985.

Figure H.1 — NPSHR reduction for pumps handling hydrocarbon liquids and high temperature water

Annex I (informative)

Statistical evaluation of measurement results

I.1 Symbols

Additional symbols used in this annex are shown in Table I.1

Table I.1 — Additional symbols

Symbol	Definition
a, r	Statistical parameters
a', r'	Statistical parameters
h	Total head test point ratio $h = \frac{H}{H_G}$
\bar{h}	Mean value of total head ratio $\bar{h} = \frac{1}{N} \sum h$
N	Number of test points in the range 0,95 Q_G up to 1,05 Q_G
p	Pump input test point ratio $p = \frac{P}{P_G}$
\bar{p}	Mean value of pump input power ratio $\bar{p} = \frac{1}{N} \sum p$
q	Rate of flow test point ratio $q = \frac{Q}{Q_G}$
\bar{q}	Mean value of flow rate ratio $\bar{q} = \frac{1}{N} \sum q$
S_q	$S_q = \sum (q - \bar{q})^2$
S_h	$S_h = \sum (h - \bar{h})^2$
S_p	$S_p = \sum (p - \bar{p})^2$
S_{qh}	$S_{qh} = \sum (q - \bar{q})(h - \bar{h})$
S_{qp}	$S_{qp} = \sum (q - \bar{q})(p - \bar{p})$
NOTE The summations above are for test point measurements in the range 0,95 Q_G to 1,05 Q_G .	

I.2 Usage and validity of this annex

Statistical analysis of two variables may be used to evaluate the mean value of one at a given value of the other. The particular statistical method presented in this annex may be applied if the distribution of test points about the specified value meets certain requirements.

I.3 Number and distribution of sets of observations

A minimum of nine sets of observations shall be taken. The resulting test points shall be distributed such that when corrected to the specified speed of rotation or the specified frequency using 6.1.2, measurements of flow rate shall span $\pm 5\%$ of the specified rate of flow. Of these test points, at least three shall be in the positive 3% to 5% flow rate band and at least three shall lie in the negative 3% to 5% flow rate band.

For ease of application of the statistical method, it is beneficial to take more than the minimum number of test points in the $\pm 5\%$ specified rate of flow band. Twenty points are recommended where this is practical.

I.4 Evaluation of mean values

I.4.1 Mean value of pump total head

The mean value of pump total head is calculated using the equation:

$$H_m = [\bar{h} + a(1-\bar{q})]H_G$$

I.4.2 Mean value of pump input power

The mean value of the pump input power is calculated using the equation:

$$P_m = [\bar{p} + a'(1-\bar{q})]P_G$$

I.4.3 Evaluation of test results

The values of the statistical parameter are given by the following equations:

$$a = r + \left[\frac{r^2 + 1}{S_{qp}^2} \right]^{1/2} \cdot S_{qp}$$

$$a' = r' + \left[\frac{r'^2 + 1}{S_{qp}^2} \right]^{1/2} \cdot S_{qp}$$

$$r = \frac{S_h - S_q}{2 \cdot S_{qh}}$$

$$r' = \frac{S_p - S_q}{2 \cdot S_{qp}}$$

NOTE The equations for a and a' contain S_{qh} and S_{qp} respectively to ensure that positive or negative values appropriate to the slope of the performance curve will be obtained.

It should be mentioned that statistical analysis may also be used to evaluate from sets of observations taken according to I.3 the 95% confidence interval of total head and input power at the specified flow rate. This is described in more detail in reference [17] where also a computer program is given to facilitate the calculations.

Annex J (informative)

Pump test sheet

The pump test sheet illustrated in this annex is given for guidance for presenting pump test results and to assist in their interpretation. It does not purport to include all the information required from a pump test and modifications may be necessary depending on the type of pump, its application, and the mode of calculation.

PUMP TEST SHEET		Sheet Number				Nature of test								
Purchaser														
	Type	Manufacturer's order number				Order number	Inlet diameter							
Pump							Outlet diameter							
							Impeller diameter							
Guaranteed values	Rate of flow (Q_G)	Speed of rotation (n_{sp})				Power input (P_G)								
	Total head (H_G)	Efficiency (η_G)				Net positive suction head (NPSH)								
Pumped liquid	Temperature (t)	Vapour pressure (p_v)				Kinematic viscosity (ν)								
	Density (ρ)					Degree of acidity (pH)								
Motor	Manufacturer			Test certificate			Number of phases			Voltage				
	Type			Power			Speed of rotation			Current				
		Rate of flow	Inlet head	Outlet head	(NPSH)	Torque	Power	Speed of rotation	Gear					
Measuring method	Method used													
	Constant													
Test conditions	Ambient temperature		Barometric pressure			Head correction to reference plane			Inlet					
	Temperature of test liquid								Outlet					
Result of measurement			Units	1	2	3	4	5	6	7	8	9	10	11
	Speed of rotation													
	Time interval													
Rate of flow	Reading													
	Measured flow													
	Outlet head reading													
	Inlet head reading													
	Outlet head													
	Inlet head													
Head	$\Delta U^2/2g$													
	Difference of measuring position													
	Pump total head													
	$U_1^2/2g$													
	(NPSH)													
	Pump power output P_U													
	Voltage													
	Current													
	Wattmeter reading 1													
	Wattmeter reading 2													
	Total of wattmeter readings													
Power (torque)	Motor power input													
	Motor efficiency													
	Torque reading													
	Gear efficiency													
	Motor power output													
	Pump power input													
	Overall efficiency													
	Pump efficiency													
Values referred to	Volume rate of flow													
specified speed of	Total head													
rotation	Power													
	NPSH													
NOTES			Date	Chief of tests			Representatives							
							of the purchaser			of the supplier				

Annex K (informative)

Checklist

The following is a checklist of items where agreement is recommended between manufacturer/supplier and purchaser before the test. It should be noted that it will not always be necessary to agree upon all these items during the elaboration of the contract.

- 1) Choice of grade of test (see 5.1)
- 2) Extent of guarantees:
 - a) Pump without motor or combined motor pump unit (see 10.4.3)
 - b) Pump with or without fittings (see 5.3.4)
 - c) Guaranteed values (e.g. flow rate, total head, power input, efficiency, NPSHR, etc.) for one or several operating points (see 4.1)
- 3) Contractual questions, such as number of pumps to be tested in a batch of identical pumps (see 5.1.2)
- 4) Any other aspect of pump behaviour to be checked during the test (see 5.2.6)
- 5) Location of tests (see 5.2.2)
- 6) Date of tests (see 5.2.3)
- 7) Person in charge of test when test is not carried out at manufacturer's works (see 5.2.4)
- 8) Choice of methods of measurement (see clauses 7 to 10)
- 9) Testing equipment (see 5.2.7)
- 10) Test arrangement for performance test (see 5.3.2, 5.3.3, 8.2.1) and for cavitation test (see 11.2.3)
- 11) Arrangement for proving priming ability of self-priming pumps (see 5.3.7)
- 12) Method of prediction of pump performance from a test using clean cold water (see 5.4.5)
- 13) Rotational speed deviation outside permissible range (see 5.4.3, 6.1.2)
- 14) Exponent of the translation formula for NPSHR (see 6.1.2)
- 15) Voltage and frequency deviations outside permissible tolerance (see 6.1.2)
- 16) Values of tolerance at duty point and other operating points (see 4.1, 6.3, 11.3.3)
- 17) Inlet and transmission losses in vertical well pumps (see 8.2.3, 10.4.2)
- 18) Friction and singular pressure losses at inlet and outlet (see 8.2.4 and annex C)
- 19) Cable losses (see 10.4.1)
- 20) Gear losses (see 10.4.4)
- 21) Method of verification of guarantees in respect to cavitation (see 11.1.2)
- 22) Liquid to be used for performance test (see 4.2) and for cavitation test (see 11.2.3)
- 23) Test costs (see annex F)

Bibliography

- [1] ISO 31 (all parts), *Quantities, units and symbols*.
- [2] ISO 2372, *Mechanical vibration of machines with operating speeds from 10 to 200 rev/s — Basis for specifying evaluation standards*.
- [3] ISO 2975-1, *Measurement of water flow in closed conduits — Tracer methods — Part 1: General*.
- [4] ISO 2975-2, *Measurement of water flow in closed conduits — Tracer methods — Part 2: Constant rate injection method using non-radioactive tracers*.
- [5] ISO 2975-3, *Measurement of water flow in closed conduits — Tracer methods — Part 3: Constant rate injection method using radioactive tracers*.
- [6] ISO 2975-6, *Measurement of water flow in closed conduits — Tracer methods — Part 6: Transit time method using non-radioactive tracers*.
- [7] ISO 2975-7, *Measurement of water flow in closed conduits — Tracer methods — Part 7: Transit time method using radioactive tracers*.
- [8] ISO 3740, *Acoustics — Determination of sound power levels of noise sources — Guidelines for the use of basic standards*.
- [9] ISO 3744, *Acoustics — Determination of sound power levels of noise sources using sound pressure — Engineering method in an essentially free field over a reflecting plane*.
- [10] ISO 3745, *Acoustics — Determination of sound power levels of noise sources — Precision methods for anechoic and semi-anechoic rooms*.
- [11] ISO 3746, *Acoustics — Determination of sound power levels of noise sources using sound pressure — Survey method using an enveloping measurement surface over a reflecting plane*.
- [12] ISO 3945, *Mechanical vibration of large rotating machines with speed range from 10 to 200 r/s — Measurement and evaluation of vibration severity in situ*.
- [13] ISO 4185, *Measurement of liquid flow in closed conduits — Weighing method*.
- [14] ISO 6081, *Acoustics — Noise emitted by machinery and equipment — Guidelines for the preparation of test codes of engineering grade requiring noise measurements at the operator's or bystander's position*.
- [15] IEC 60041:—³⁾, *International code for the field acceptance tests of hydraulic turbines*.
- [16] IEC 60497, *International code for model acceptance tests of storage pumps*.
- [17] E. Grist and R. P. Hentschke, *The Verification of Centrifugal Pump Performance Guarantees by Acceptance Tests — An Alternative Method*. *I.Mech.Eng. London*, March 1989.

³⁾ To be published. (Revision of IEC 60041:1992)